



## **2024 – SCOTTISH LEGENDS CARS CHAMPIONSHIP SPORTING & TECHNICAL REGULATIONS PUBLISHED COPY**

IMPORTANT NOTE TO COMPETITORS AND ALL OFFICIALS:

PURSUANT TO 2024 NCR A.2.4 THIS CHAMPIONSHIP AND ALL ITS EVENTS ARE BEING RUN AS TRIAL EVENTS UNDER THE 2025 MOTORSPORT UK ('ASN') NATIONAL COMPETITION RULES ('NCR').

WITH LIMITED EXCEPTIONS REFERRED TO IN THESE CHAMPIONSHIP REGULATIONS THE NCR APPLY IN SUBSTITUTION FOR THE 2024 ASN GENERAL REGULATIONS.

ALL PARTICIPANTS MUST ACQUAINT THEMSELVES WITH THE NCR AND WHICH ARE ONLY AVAILABLE ONLINE AND CAN BE FOUND HERE: <https://www.motorsportuk.org/the-sport/trialncr/>

ALL REGULATORY REFERENCES IN THESE CHAMPIONSHIP REGULATIONS (AND WHICH REGULATIONS ARE AN 'OFFICIAL DOCUMENT') ARE TO THE 2025 NCR.

THE RELEVANT NCR ARE: CHAPTERS 1 -11 AND 12 -RACE

COMPETITORS AND OFFICIALS SHOULD REGULARLY CHECK THE ABOVE WEBLINK FOR ANY REVIEWED NCR AND WHICH MAY ALSO BE PUBLISHED BY CHAMPIONSHIP BULLETINS AS OFFICIAL DOCUMENTS.

REGULATORY QUERIES MAY BE ADDRESSED TO THE CHAMPIONSHIP ORGANISER OR ASN LEGAL: [ncr@motorsportuk.org](mailto:ncr@motorsportuk.org) AND WILL BE ADDRESSED BY EITHER SIAN WOOLLEY, ASSISTANT LEGAL COUNSEL OR JAMIE CHAMPKIN REGULATORY COUNSEL AND DISCIPLINARY OFFICER.

## **CONTENTS**

1. SPORTING REGULATIONS - GENERAL	Page 3
1.1 Title & Jurisdiction	Page 3
1.2 Official	Page 3
1.3 Competitor Eligibility	Page 3
1.4 Registration	Page 4
1.5 Championship Events	Page 5
1.6 Scoring	Page 6
1.7 Awards	Page 7
2. CHAMPIONSHIP EVENT & RACE PROCEDURES	Page 8
2.1 Entries	Page 8
2.2 Briefings	Page 8
2.3 Qualification Practice	Page 8
2.4 Races	Page 9
2.5 Starts	Page 10
2.6 Session Red Signal	Page 11
2.7 Pit, Paddock & Pitlane Safety	Page 11
2.8 Race Finishes	Page 12
2.9 Results	Page 12
2.10 Timing Modules	Page 12
2.11 Qualification Races	Page 12
2.12 Operation of Safety Car	Page 13
2.13 Onboard Cameras	Page 13
3. SPECIFIC CHAMPIONSHIP REGULATIONS	Page 14
4. SPECIFIC CHAMPIONSHIP PENALTIES	Page 14
5. TECHNICAL REGULATIONS	Page 17
5.1 Introduction	Page 17
5.2 General Description	Page 17
5.3 Safety Requirements	Page 19
5.4 General Technical Requirements & Exceptions	Page 20
5.5 Chassis	Page 21
5.6 Bodywork	Page 22
5.7 Engine	Page 25
5.8 Suspension	Page 32
5.9 Transmission	Page 33
5.10 Electrics	Page 35
5.11 Brakes	Page 36
5.12 Wheels/Steering	Page 37
5.13 Tyres	Page 38
5.14 Weights	Page 38
5.15 Fuel Tank/Fuel	Page 38
5.16 Silencing	Page 39
5.17 Numbers and Championship Decals	Page 40
6. APPENDICES	Page 41
6.1 Race Organising Clubs & Contacts	Page 41
6.2 Commercial Undertakings	Page 41
6.3 Trade Support Car Decals & Overall Patches	Page 42
6.4 Promotional Activities	Page 42
6.5 Parts List & Diagrams	Page 43
7.0 REGISTRATION FORM	Page 56
8.0 Motorsport UK Technical Exemption	Page 58

# 1. SPORTING REGULATIONS – GENERAL

## 1.1 TITLE & JURISDICTION:

The Scottish Legends Cars Championship is organised and administered by the Knockhill Motor Sports Club (KMSC) (“the Organiser”) in accordance with the **National Competition Rules (NCR)** of Motorsport UK (“the ASN”) (incorporating the provisions of the International Sporting Code of the FIA) and these Championship Regulations.

**ASN** Championship Permit No. **CH2024/R109** Race Status: Interclub

**ASN** Championship Grade: D

## 1.2 OFFICIALS: (see appendix for contact information)

1.2.1 Co-ordinator: **Heather Barron**  
Deputy Co-ordinator: Steve Burns

1.2.2 Licensed Eligibility Scrutineer: **Gordon Hay**  
**Tel. 07740 243100** **E-mail. gordonehay@hotmail.co.uk**

1.2.3 Championship Stewards: Alan Brunton, Gordon Shedden, Jillian Shedden  
**Championship Stewards**  
***NCR Chapter 4 App.1 Art.2 The Championship Stewards can only adjudicate upon any disputes irregularities or appeals arising from the published Championship Regulations. They are also empowered to consider any request from the Championship Co-ordinator to penalise any Competitor for breach of Championship Regulations and after holding a formal hearing those Stewards may impose a penalty in accordance with Chapter 2 subject to the rights of Appeal to the National Court there provided.***

## 1.3 COMPETITOR ELIGIBILITY:

1.3.1 Entrants must:

- (a) be fully paid-up valid RACING membership Card holding members of the Knockhill Motor Sports Club and
- (b) be Registered for the Championship and
- (c) be in possession of a valid **ASN** Entrants Licences.

1.3.2 Drivers and Entrant/Drivers must:

- (a) Be current RACING Members of the Knockhill Motor Sports Club and
- (b) be Registered for the Championship and
- (c) be in possession of valid **ASN** Competition (Racing) Club status licence, as a minimum
- (d) Or **if the holder of a foreign ASN Competition licence** then be in possession of the highest grade of national Race licence or valid FIA International Licence, together with their ASN’s written consent (**NCR Chapter 6 App.3 Art.6** and FIA ISC Article 2.3.7.b applies)
- (e) If participation in the Championship requires absence from education a Driver, in full time school education is required to have the approval of their head teacher and a letter stating such approval from their school to fulfil registration for the Championship. A Driver shall not take time out of their education to participate in motor sport without the prior written approval of their education establishment.

1.3.3 All necessary documentation must be presented for checking at all **Events** when signing-on.

1.3.4 There will be separate classifications and Awards for Overall and Rookies categories, both **per Race**, per Event and **to determine final Championship Results**.

1.3.5 Rookies are defined as Competitors in their first season of Legends Cars Racing.

#### 1.4 **REGISTRATION:**

1.4.1 All Competitors must register for the Championship by returning the **Championship** Registration Form with the Registration Fee to the Co-ordinator prior to the Final Closing date for the first **Event** being Entered.

Rookies (newcomers) and Teams must indicate on the **Championship** Registration form that they are Entering one of these classes.

1.4.2 The Registration Fee is £150 (one hundred and fifty pounds) - Made payable to: **Knockhill Motor Sports Club**.

1.4.3 Registration numbers will be the permanent Competition numbers for the Championship.

1.4.4 As an exception to **Art.** 1.4.1. nonregistered Drivers may compete as a non-points scoring guest. Guest Cars must comply with the Regulations and start the Races on the grid according to their Qualifying time after Practice or where the grid draw places them, if they have Raced Legends Cars previously, if not they must start at the back of the grid with the Rookies, unless Officials indicate otherwise. Guests are ignored for points scoring. They must comply with general safety regulations and these Sporting & Technical regulations. Drivers registered for the Championship cannot Enter as guests. The acceptance of Guests is at the discretion of the Organisers and Guests must not prevent the acceptance of an Entry from a registered Driver.

1.4.5 Championship Categories:  
This Championship has three points scoring categories, 'Individual', 'Rookie' and 'Team'. Points cannot be awarded retrospectively.

1.4.5.1 By Entering and registering for the Championship Drivers are automatically an 'Individual' Competitor unless categorised as a 'Rookie' in accordance with **Art.** 1.4.6. The Driver will be issued with a Race number which they must display upon whichever Car they are Driving irrespective of whether the Car is self-owned, hired or borrowed.

1.4.5.2 Drivers electing to compete as a 'Team' must each register per the conditions in **Art.** 1.4.1 making it clear that it is a team registration. Racing as a team means that two or more Drivers must share one Car and it will be the 'Car' that Carries the Race number. Drivers Entering as a Team must hold a valid Entrants licence in accordance with **NCR Chapter 4 Art.16** and will not be eligible for individual Driver Awards in the Championship. Each Driver must Enter the round they drive in.

If a Team Entry fails to fulfil the criteria of a minimum of 2 Drivers Racing one Car by the end of the season, then the Driver is removed from the Team class and joins the individual class, with a penalty **deduction** of 400 points. The registered **Car** must be used.

The Car cannot be substituted unless it is proven to be a write off (damaged beyond **economical** repair) and with the permission of the Championship Co-ordinator and / or **Championship** Eligibility Scrutineer. The substitute **Car** must be scrutineered separately before use in any Race or Qualifying session.

- 1.4.5.3 All points and any Penalties will be Awarded to that 'Car' and shared, in effect, by all the Drivers within the Team. Any Driver within the Team who is classified as a Newcomer or 'Rookie' shall be subject to the provisions of novice stature (Art. 1.4.6) and shall be eligible for Driver Class Awards. Teams will only be allowed to Enter one Driver in each **Event**.
- 1.4.5.4 A Driver must compete as either 'Individual', 'Rookie' or as a 'Team' member or Guest. Drivers cannot Enter **multiple** classes at the same time. They may switch from one category (Individual, Rookie or Team) to the another at any point providing that notification of the change has been given to the Championship Co-ordinator, in writing, at least 10 days before it takes effect. Points gained in one **class** cannot be transferred to another.
- 1.4.6 **New Driver Class (Rookies):**  
All Drivers Entering their first Race in a Legends Car competitively shall be classified as a 'Rookie' for that **Championship** season and must start at the back of the grid for the first twelve (12) Races. Rookies must also indicate their Rookie (Newcomer) status on the **Championship** Registration Form and on the Entry form for each **Event**. Any driver who starts a Championship **Event** as a Rookie will remain a Rookie until the completion of that **Event** ie. all 3 races.
- 1.4.7 Drivers **may** elect to start from the back 1/3<sup>rd</sup> of the grid during a Championship **Event**. Drivers in this category start after the registered Championship contenders but ahead of Rookies with less than 12 starts and guests. They must indicate this preference on the Entry form. This will be possible for **Events** with grids drawn by ballot, but only for Heat 1 with **Event Races** using the alternative timed grid allocation method.

## 1.5 **CHAMPIONSHIP EVENTS / RACES:**

The Championship will be contested over **13 Events** as follows:

Date:	Circuit / Venue:	Round:	Organising Club:
20 <sup>th</sup> April 2024	Knockhill Clockwise	1	KMSC
21 <sup>st</sup> April 2024	Knockhill Clockwise	2	KMSC
18 <sup>th</sup> May 2024	Croft	3	DDMC
19 <sup>th</sup> May 2024	Croft	4	DDMC
1 <sup>st</sup> June 2024	Knockhill Anti-Clockwise	5	KMSC
2 <sup>nd</sup> June 2024	Knockhill Clockwise	6	KMSC
6 <sup>th</sup> July 2024	Knockhill Clockwise	7	KMSC
7 <sup>th</sup> July 2024	Knockhill Clockwise	8	KMSC
17 <sup>th</sup> August 2024	Oulton Park International	9	MSVR
7 <sup>th</sup> September 2024	Knockhill Anti-Clockwise	10	KMSC
8 <sup>th</sup> September 2024	Knockhill Clockwise	11	KMSC
5 <sup>th</sup> October 2024	Knockhill Clockwise	12	KMSC
6 <sup>th</sup> October 2024	Knockhill Clockwise	13	KMSC

Each **Event comprises** 3 races: Heat 1, Heat 2 & Final.

## 1.6 SCORING:

1.6.1 Points will be Awarded to Competitors listed as classified finishers in the Final Results per Race as follows:

1 <sup>st</sup>	200 points	10 <sup>th</sup>	100
2 <sup>nd</sup>	185	11 <sup>th</sup>	90
3 <sup>rd</sup>	170	12 <sup>th</sup>	80
4 <sup>th</sup>	160	13 <sup>th</sup>	70
5 <sup>th</sup>	150	14 <sup>th</sup>	60
6 <sup>th</sup>	140	15 <sup>th</sup>	50
7 <sup>th</sup>	130	16 <sup>th</sup>	40
8 <sup>th</sup>	120	17 <sup>th</sup>	30
9 <sup>th</sup>	110	18 <sup>th</sup>	20

All other classified finishers will receive 10 points and all other starters who are non-finishers 5 points, unless they were Disqualified. Drivers Entering as 'Guest' Drivers do not score any points, but are eligible for trophies in individual **Races / Events**.

1.6.2 The totals from all Qualifying Events will determine final Championship points and positions. Three Races make up each Championship **Event**. The three Races will consist of 2 Heats (6, 7, 8 **or 10** laps) and a Final (8, 10 **or 12** laps). Race distances will be confirmed in the **Official Documents**. Grid positions in Heat 1 should be determined by ballot drawn by the Championship Co-ordinator or a nominee. Heat 2 the grid is reversed. The Final has the lowest scoring Cars of Races 1 and 2 on pole and the highest at the back of the grid, ahead of any Rookies Drivers electing to start by choice in the rear of the grid.

1.6.2.1 Drivers electing to start in the final 1/3rd of the grid must notify the Championship Co-ordinator of their decision prior to that **Event** commencing. By doing so they will start after the main Championship Drivers and ahead of any Guest who is a Rookie and Rookie Drivers (who have Raced in less than 12 Legends Cars Races), unless they are also a Rookie, when they will start in their allocated grid slot.

1.6.2.2 Championship points and Awards will be scored as per **Art** 1.6.1 above. In the event of a tie at any Championship Event, Championship points will be divided equally between the tied places; however, a tie break system, outlined below, will be employed on the day to determine the trophy positions of Competitors who tie within the top three positions. This will be as follows:

1.6.2.3 The system, in the first place, will be based on the number of Cars that each Competitor has overtaken in both Races. The Drivers classified finish position will be subtracted from their balloted grid position to give a figure for their 'improvement' in each Race. (i.e. if a competitor started 11<sup>th</sup> on the grid and finished 3<sup>rd</sup> their 'improvement' would be  $11 - 3 = 8$ ). The Competitor with the highest 'improvement' factor across both Races, when added together, would be the winner of the tie break for trophy purposes only.

1.6.2.4 If the situation is still tied after this calculation then, for the second tie break, the Competitor with the highest finishing position in their first Race would win the trophy for the tied position. If the position is still tied then the highest position in the second Race would be the determining factor.

1.6.2.5 If the position is still tied, then the highest position in the Race that the competitors raced together will be the final determining factor.

- 1.6.2.6 NB: The system outlined above is solely for determining the trophy positions on the day and does not affect the Award of overall Championship points for that day.
- 1.6.3 Ties shall be resolved using the formula in **NCR Chapter 4 App.3 Art.27.**
- 1.6.4 Where the Race distance has been reduced (2.6) it shall still count as a full points scoring round.
- 1.6.5 Competitors not registered for the Championship may be permitted on an individual basis and will:
- (a) be deemed "Guest Competitors" (Article 1.4.4)
  - (b) not score points and for the purpose of points scoring will be ignored
  - (c) qualify for Event Awards
  - (d) comply with the eligibility criteria as prescribed in Article 1.3 above, with the exception of 1.3.1 (a) and 1.3.2 (b), as appropriate.
- 1.7 **AWARDS:**
- 1.7.1 All Awards are to be provided by the KMSC.
- 1.7.2 Per **Event:**  
Trophies to 1<sup>st</sup>, 2<sup>nd</sup> & 3<sup>rd</sup> plus the highest finishing 'Rookie'  
**Highest placed** Driver electing to start from the back 1/3<sup>rd</sup> of the grid during a Championship round).
- 1.7.3 Championship:  
Trophies to the Overall Championship 1<sup>st</sup>, 2<sup>nd</sup> & 3<sup>rd</sup> place Drivers  
Newcomer (Rookie) Award (Drivers in their first season of Legends Cars racing)  
Team Championship (provided there are at least 3 team entries).
- 1.7.3.1 Bonuses:  
The Organisers reserve the right to arrange and introduce additional bonus Awards during the championship.
- 1.7.4 Presentations:  
Awards will be presented at the end of each Event, and/or at the end of the Championship at the designated presentation ceremony. All Drivers taking part in podium presentations must be wearing racing suits. Failure to attend any prize giving ceremony may result in forfeiture of Awards.
- 1.7.5 Entertainment Tax Liability.  
Prize money and Bonuses shall be posted to the Entrants within 7 days of the results being declared final after each Event.
- In accordance with current government legislation, the Organiser of each round are legally obliged to withhold tax at the basic rate on all payments to non-UK resident sportsmen/women and account to HMRC using form FEU1, the quarterly return of payments made to non- resident entertainers and sportsmen/women.
- That is, those persons who do not have a normal permanent residence in the UK. The UK does not include the Isle of Man, Channel Islands or Eire. This means that the Organiser **is** required to deduct tax at the current rate applicable from any such payments they may make to non-UK residents.

Under certain circumstances, it may be possible for Competitors to enter into an agreement with the Inland Revenue to limit the tax withheld. Any application for such an arrangement must be made in writing and not later than 30 days before the payment is due. For further information contact: HMRC Personal Tax International, Foreign Entertainers Unit, St John's House, Merton Road, Liverpool L75 1BB. Tel: 0151 472 6488 F 0151 472 6483.

- 1.7.6 Title to all Trophies:  
If Provisional Results or Championship Tables are revised after any presentations and these revisions affect the distribution of Awards the Competitors concerned must return them to the Organiser in good condition within 7 days.

## 2. CHAMPIONSHIP EVENT & RACE PROCEDURES

### 2.1 ENTRIES:

- 2.1.1 Competitors are responsible for sending in correct and complete entries with the correct Entry fee prior to the closing date for entries before each Event.
- 2.1.2 Incorrect or incomplete entries (Including Driver to be Nominated Entries) **will** be held in abeyance until they are complete and correct and the date of receipt for acceptance of Entry purposes shall be the date on which the **Event** Organiser receives the missing or corrected information or **Entry** Fee.
- 2.1.3 Any withdrawal of Entry or Driver/Car changes made after acceptance of any Entry must be notified to the **Event** Organisers in writing. **NCR Chapter 3 App.11 Art.11.** applies.
- 2.1.4 The Entry Fee for each Event shall be specified in the **Official Documents** and on the Entry form.
- 2.1.5 Entries will be accepted on a first come first served basis up to the maximum number permitted to Race on the **ASN** Track Licence for the Event in question. No reserves will be accepted.

### 2.2 BRIEFINGS:

Organisers should notify Competitors of the times and locations for all briefings in the **Official Documents** for the **Event**. Competitors must attend all briefings.

### 2.3 QUALIFICATION PRACTICE:

- 2.3.1 Should any Practice session be disrupted the Clerk of the Course shall not be obliged to resume or re-run the session; the decision of the Clerk of the Course shall be final.
- 2.3.2 Each Driver shall complete a minimum of 3 laps in the Car to be Raced, and in the correct session, in order to Qualify and assume his or her balloted grid position. Where a Driver fails to Qualify in the correct session, **they** will need to satisfy the Clerk of the Course that the requirements of **NCR Chapter 12, App.6 Art.11** are met and will start from the back of the grid for the Race in whichever Race their balloted grid position is nearest to the front. Should the Clerk of the Course and/or the **Event** Stewards deem that this subsequently creates a gap or gaps on the grid that may compromise the safety of the Race start, they may order that all Cars assume their balloted grid position by reason of force majeure. In such cases, this Decision would apply for all Races within a Championship **Event**.



- 2.3.3 The Clerk of the Course and/or the **Event** Stewards shall have the right to Disqualify any Driver whose driving is considered to be unsatisfactory – per **NCR Chapter 12, App.6 Art.15** – or may instruct the Driver to start from the pit lane for the first Race. The situation may be reviewed in respect of the start position of the second Race. If the Competitor has incurred an infringement in familiarisation or Practice, or their pace was not of the required standard, the Clerk of the Course and/or **Event** Stewards may instruct the Driver to start from the pit lane for all Races.
- 2.3.4 GRID DRAWN BY BALLOT - Practice times set will not count towards the starting grid position. These will be determined by a blind draw prior to the first Race. Competitors will be notified of their grid standing by means of a bulletin (**Official Document**) posted on the Official notice board. In all Races there are certain Competitors who start after the main grid. These are Drivers electing to start **in the final 1/3rd of the grid (Art. 1.6.2.1.)**, then Rookies with less than 12 starts and finally guests who start at the back of all grids.
- 2.3.4.1 ALTERNATIVE TIMED GRID - To be used only if a grid drawn by ballot is not available. Grid based on practise / familiarisation times for Heat 1, with top 10 classified finishers in Heat 1 in a reversed grid in Heat 2 (10<sup>th</sup> placed finisher on pole, 9<sup>th</sup> placed in 2<sup>nd</sup> etc.) and top 10 classified finishers in Heat 2 in a reversed grid for the Final. Only one method of grid determination will be used per **Event**. Competitors will be notified of their grid standing by means of a bulletin (**Official Document**) posted on the Official notice board.
- 2.3.5 The grid for the final Races will be determined from the aggregate result (points scored) of the Qualification Races, with the lowest points at the front and the highest at the back of the grid. Where this process results in tied scores the grid position will be resolved by reference to the fastest lap set in the Heats. In every Race the Rookies (Newcomers Class) and Guests will form up behind the last Driver except where that Driver is at the back of the grid as a Penalty.
- 2.3.6 Registered Competitors are not permitted to Practice in a Legends Car at any specific Circuit hosting a round of the Championship for a period of 7 days prior to the date of the Championship **Event**, except for official pre-Event Practice or PR sessions organised by the Organiser / Circuit. The exception is where the Circuit is being used in a different configuration or a different direction to that of the Race, or for a corporate / promotional / race school / non Championship Event. Competitors should contact **the** Championship Co-ordinator to advise **them** of the on track activity.
- 2.4 **RACES:**
- Should any race be disrupted the Clerk of the Course shall not be obliged to resume or rerun the Race (**NCR Chapter 12, App.6 Art.49**) (**Art.** 1.6.4. above applies).
- 2.4.1 The standard minimum scheduled distance shall be no less than 5 laps (specified as a number of whole laps) but should any Race distance be reduced at the discretion of the Clerk of the Course or **Event** Stewards it shall still count as **a** full points scoring **Event**. Each **Event** of the Championship **is intended** to consist of 3 Races, these being two 5, 6, 7, 8 **or 10** lap Heats and an 8, 10 **or 12** lap Final. The Event Organiser may amend this.

## 2.5 STARTS:

All cars **must** be in the Assembly Area 10 minutes prior to their Race, thus allowing Cars to be positioned in their respective place on the dummy grid. At the point that the Cars are released on to the grid any Competitor who is not ready may be required to start from the pit lane in accordance with **Art.** 2.5.3.

2.5.1 Cars will leave the Assembly Area behind the Leading Car to start their rolling lap(s). The exact procedure will be outlined in the Drivers Briefing for each Event.

2.5.2 Towards the end of the Rolling Lap(s) the Leading Car will leave the **Track** after extinguishing its roof lights indicating a start is imminent. The grid will continue at a similar speed on the approach to the start line. Cars must maintain the speed set by the Leading Car prior to it accelerating away to leave the **Track**. Any visible increase in speed of the front row of the grid prior to the red light **Signal** being extinguished will be deemed to be an infringement and may result in a Time Penalty being applied. The same Penalty may apply to any Car breaking rank/formation before passing the startline. Any car creating an unnecessary gap between itself and the Car in front on a Race start (or re-start) may be deemed to be out of position and given a Time Penalty. The start may be aborted by the Clerk of the Course after the Leading Car has pulled off the **Track** in accordance with **Art.** 2.5.6.

2.5.3 Any Drivers unable to start the Green **Signal**/Formation lap within 30 seconds of the Leading Car starting the rolling lap(s) will be allowed to start from the pit exit after the last Car to take the start has passed the exit point.

2.5.4 Any Driver unable to maintain grid positions on the Green **Signal** Lap, to the extent that ALL other cars are ahead of them, may complete the Green **Signal** lap but MUST remain at the rear of the last row of the grid

2.5.5 In the event of any starting lights failure the Starter will revert to use of the National Flag.

2.5.6 Aborted Start:

If the start is aborted prior to the Leading Car pulling off, the Leading Car will not extinguish his roof lights and will continue to lead the field around the **Track** for an additional lap and a new start will be attempted. The Race will not start until the Leading Car pulls off of the **Track**, the signal to start will not be given, and the start **Signal** lights may remain at red.

If the start is aborted after the Leading Car has pulled off the **Track**, the signal to start will not be given, the start **Signal** lights will remain at red and all Cars should exercise extreme caution and return slowly round the **Track** maintaining their original grid positions and stopping on the grid. The Race start procedure will then be repeated from the showing of the one-minute board indicating that the green **Signal**/formation lap is imminent. At the discretion of the Clerk of the Course, the Race distance may be reduced accordingly.

2.5.7 Excessive weaving to warm-up tyres - using more than 50% of the Track width, and falling back in order to accelerate and practice starts - is prohibited.

## 2.6 **SESSION RED SIGNAL:**

Should the need arise to stop any Race or Practice, RED LIGHT SIGNALS will be switched on at the Startline and RED SIGNALS will be displayed at the Startline and at all Marshals Signalling Points around the Track.

This is the signal for all drivers to cease circulating at Racing speeds, to slow to a safe and reasonable pace and to return to the pit lane, during Practice, and to the starting grid area, during a Race, unless otherwise directed by Officials.

Cars should not enter the Pits unless directed to do so and all Cars in the pit lane during a red Signal period must take any restart from the pit exit.

## 2.7 **PITS, PADDOCK & PIT LANE SAFETY:**

### 2.7.1 Pits & Paddock:

Competitors must ensure that the ASN, Circuit Management and Organising Club Safety Regulations are complied with at all times.

### 2.7.2 Pitlane:

The outer lane or lanes are to be kept unobstructed to allow safe passage of Cars at all times. The onus shall be on all Drivers to take all due care and respect the pit lane speed limits.

### 2.7.3 Refuelling:

May only be carried out in accordance with the NCR, the Organising Club Regulations, Circuit Management Regulations and the Official Documents issued for each Circuit / Event.

### 2.7.4 Speed Limit:

Pit Lane Speed Limit will be 60kph.

## 2.8 **RACE FINISHES:**

After taking the Chequered Flag Drivers are required to:

- I. progressively and safely slow down
- II. remain behind any Competitors ahead of them,
- III. return to the Pit Lane Entrance/Paddock Entrance as instructed,
- IV. comply with any directions given by Marshals or Officials
- V. keep their helmets on and harnesses done up while on the Track or in the pitlane.

2.8.1 **PARC FERME** After each Qualifying / familiarisation session / Race the Cars must be presented directly for scrutineering. Any area deemed necessary by the Championship Eligibility Scrutineer or nominated representative will be subject to Parc Fermé conditions with no exceptions. This will include the Track from the Finish Line to the scrutineering area; the waiting area in front as well as the Track from the scrutineering area to Parc Fermé, but all areas may be used as necessary. Any Car finishing a Race under its own power that does not report through Parc Fermé will be classed as DNF for that Race, irrespective of its actual finishing place on the Track.

- 2.8.2 Public and team personnel must not enter Parc Fermé unless invited by the Championship Eligibility Scrutineer or nominated representative. Should unauthorised Team / **Entrant** personnel be present in these areas, the breach will be reported to the **Stewards** who may impose Penalties as appropriate. This restriction will also apply when Team facilities are utilised as the nominated Parc Fermé area.
- 2.8.3 If blowers are required to cool the engines they are to be passed to the Driver who will attach it to the Car. Cars must remain in the designated Parc Fermé until formally released by the Championship Eligibility Scrutineer, or nominated representative. The Eligibility Scrutineer may allow one Team member / **Entrant support person** to enter Parc Fermé.
- 2.8.4 In the event that the Championship Eligibility Scrutineer requires a Competitor to strip or remove a part from a Competitor's **Car** then only one Team member may undertake the work, the Driver may be present as well. If additional Team personnel are required this will be at the discretion of the Eligibility Scrutineer.

## 2.9 **RESULTS:**

All Practice Timesheets, Grids, Race Results are to be deemed Provisional until all **Cars** are released by Scrutineers after Post Practice/Race Scrutineering and/or after completion of any Judicial or Technical Procedures. (**NCR Chapter 3 App.6 Art.4**).

## 2.10 **TIMING MODULES:**

- 2.10.1 Timing at all events will be by Electronic Competitor Identification Modules (Transponders) and Light Beam Timing Systems operated by **ASN** Licensed Timekeepers (**NCR Chapter 12 App.6 Art.5-10**).
- 2.10.2 Each competitor is responsible for having their **Car** fitted with a working **Car** identification module (transponder) and for submitting the Identification Number of that module on their Entry Form. Failure to do so can lead to a Competitor being Disqualified from any Practice and Race Results. When one Car is double Entered, each Competitor must fit and Register on their Entry Form their individual Transponder Identification Number.
- 2.10.3 The nationally required transponder is a MyLaps X2 or TR2 Car transponder. Previous iterations which are acceptable are a Mylaps Tranx260 unit or a MyLaps Car personal transponder. (The Direct Powered options are recommended as the rechargeable units have a limited battery life).
- 2.10.4 To assist new Competitors in motorsport a transponder may be hired from SMART Timing for their first Event only (at Knockhill). All other Competitors are responsible for procuring and fitting a transponder and recording its Identification Number on the Entry Form.
- 2.10.5 Information and advice on approved types of transponders, sources of supply and the required location and fitting of transponders for each class of Car are available to Competitors and/or Entrants from the Championship Co-ordinator or SMART Timekeeping (Email [sharpy@compuserve.com](mailto:sharpy@compuserve.com)).

## 2.11 **QUALIFICATION RACES:**

If any Event is oversubscribed the Organiser may at their discretion run Qualification Races. The Organiser will notify Competitors in **Official Documents**.

## 2.12 OPERATION OF SAFETY CAR:

- 2.12.1 The Safety Car will be brought into operation and run in accordance with **NCR Chapter 12 App.8 Art.17-33**, but subject to the following variations:
- 2.12.2 At Knockhill, the Safety Car will be located in the Tri-Oval and it will normally join and exit the **Track** immediately after the exit from the Hairpin. If this location is to be varied at Knockhill, specific written instructions and verbal briefings will be issued detailing the exact location to be used.
- 2.12.3 At circuits other than Knockhill, the Safety Car (if used) will normally join and exit the **Track** from the Pitlane or as specified in the Organiser's **Official Documents**.
- 2.12.4 At Knockhill, the Safety Car will not join the **Track** until a Safety Car board and yellow **Signal** have been displayed at the Hairpin-In **Signal** point.
- 2.12.5 The first three laps completed during the Safety Car intervention at Knockhill **Events** will be added to the Race distance. Example, a 9 lap Race with 3 Safety Car laps will become a 12 lap Race. Any Safety Car laps above 3 laps will count as Race laps.

## 2.13 ONBOARD CAMERAS:

- 2.13.1 All Competitors are required to carry an on board camera for the primary purpose of safety. Footage from the cameras may be used where there is an incident which is subsequently **referred to** the **Stewards** for investigation. Footage should be retained until such time as the Results are declared final. The decision to review any such video footage is at the discretion of the Clerk of the Course, the **Event** Stewards or the Championship Stewards. Championship Organisers may refer Competitors to Officials.
- 2.13.2 It is the Competitor's sole responsibility to ensure safe installation and effective operation of the camera equipment. At all times cameras must be fitted in accordance with **NCR** and be approved by the Chief Scrutineer in accordance with **NCR Chapter 7 App.9**. Only cameras installed by the Official TV company on Race day are exempt from pre-Event scrutineering.
- 2.13.3 Cameras must be mounted in a central to left position with the steering wheel and front windscreen in clear view. This forms part of the pre-Event scrutineering check.
- 2.13.4 In the event that no data is available on request (other than due to a proven defect with the equipment) **Penalties** may be applied, which can include but are not limited to a fine of up to £500 and/or a points deduction of 200 **Championship** points per offence for all classes the Competitor is Registered for, even when this results in a negative score. The burden of proof to establish the cause of such failure lies with the Competitor. The **Championship Stewards** shall confirm the Championship punishment and may add further punishment. The Organiser **acting through the Championship Co-ordinator** may also seek further disciplinary action by referring a Driver to the Championship Stewards.

### 3. SPECIFIC CHAMPIONSHIP REGULATIONS:

#### 3.1 RACECEIVER:

This is an in Car one way radio system which allows Officials to warn Drivers of on track hazards. They are mandatory for all Competitors at Knockhill **Events** unless advised otherwise **by Official Document. Events** not held at Knockhill may not use RACECEIVER; this will be confirmed in instructions to competitors from the Event Organiser. RACECEIVERS must be in good working order and be able to receive communication from the Officials. **NCR Chapter 12 App.4 Art.34** applies. Any Driver not wearing a working RACECEIVER in either Practice or Race will not be allowed to take up their start position until rectified (they may start from pit lane once the RACECEIVER is working if they have run out of time to take up their rightful position). Officials may cancel the use of the RACECEIVER for any Practice or Race, Competitors will be informed by bulletin **(Official Document)**, or by the **Championship Co-ordinator** or nominee.

3.2 Each Competitor must present their engine passport at Scrutineering.

3.3 By Registering for the Championship all Competitors and their associates commit to positively promote and demonstrate the **ASN** Respect Code which is appended to these Regulations (Appendix 1).

3.3.1 Where any reports of disrespectful conduct are judged to be well founded the Championship Organiser may issue warnings or require remedial actions and/or report the matter **via the Championship Coordinator** to the Championship Stewards who may impose appropriate Penalties which can include loss of Championship points and/or Race bans through to Championship Expulsion and referral to **the ASN Disciplinary Officer who may refer the matter to the ASN National Court (NCR Chapter 2)**.

3.3.2 It is imperative that we promote the safety and wellbeing of young people and adults at risk. In addition to this all participants must be aware of their behaviour and conduct at all times and abusive language and harmful behaviour will not be tolerated. Any such incidents must be reported to the Championship Coordinator and/or Safeguarding Officer who will also relay the report to **the ASN**. Details of the **ASN** Policies and Guidelines are available at <http://www.motorsportuk.org/resource-centre> by selecting Policies and Guidelines.

### 4. SPECIFIC CHAMPIONSHIP PENALTIES:

**a) Pursuant to NCR Chapter 1 Art.4 for the purposes of a trial during the 2024 Championship the ASN has granted the following suspension substitution and variation of the National Competition Rules:**

**b) The Judicial Procedures and Authority at and for the purposes of all Championship Events and the Championship shall be those provided by the relevant provisions of the 2024 FIA International Sporting Code in substitution for the provisions of the 2024 National Competition Rules. However, offences reported by Judges of Fact (such as track limit infringements and false starts) will be reserved under the powers of the Clerk of the Course who may apply the penalties detailed in these Championship Regulations without needing to consult with or refer the matter to the Stewards.**

**c) The roles and functions of the Championship Stewards and the ASN National Court remain as provided by the 2024 National Competition Rules**

**d) Appeal Fees to the National Court in respect of Appeals against the Decisions of the Event Stewards shall be those provided by the 2024 National Competition Rules.**

**e) The Right of Review procedure is that provided by the NCR not the International Sporting Code. The Fee payable is the Protest Fee applicable to the Event.**

f) To the foregoing extent the relevant provisions of the 2024 International Sporting Code are deemed incorporated in these Regulations.

g) All Penalties will be in accordance with the current NCR and these Regulations.

h) In respect of Technical Eligibility matters the Event Stewards are the relevant Judicial Body but the Penalties and Appeals provisions of Art.4.1 – 4.2 below and the NCR apply (NCR Chapter 2 App.8 as to Technical Eligibility and Chapter 2 App. 4 apply).

Driving Standards – if a competitors driving standards fall below a reasonable standard the Officials and / or **Championship** Co-ordinator (or the deputy) may report the Competitor to the Championship Stewards who will consider further action.

#### 4.1 Infringements of Technical Regulations:

##### 4.1.1 Arising from post Practice Scrutineering or Judicial Action:

Minimum Penalty: The provisions of **NCR Chapter 2 App.8 Art.21.**

##### 4.1.2 Arising from post Race Scrutineering or Judicial Action:

Minimum Penalty: The provisions of **NCR Chapter 2 App.8 Art.26-27.**

For infringements deemed to be of a more serious nature the **Judicial body will impose the provisions of NCR Chapter 2 App.8 Art.28.** Additionally the **Championship Stewards may consider** the imposition of further penalties (**NCR Chapter 2 App.8 Art.24**) which may but are not limited to **the forfeiture of** all Championship points earned during the **Championship** up to the time of the **relevant** infringement.

#### 4.2 Additional specific Championship penalties:

If Competitors are found to be **in breach of** Regulations, the Championship Co-ordinator may **refer the matter** to the Championship Stewards for the consideration of the imposition of further Penalties.

Any offence of “**Contact with another Vehicle and / or repetition of serious mistakes or the appearance of a lack of control over the Vehicle**” (see **NCR Chapter 12 App.7 Art.8**) will result in 200 points being deducted from the **Competitor's** Championship **score** even if this results in a minus total – **in addition to** any **ASN** Penalty issued.

Should two separate offences be committed, then all **Championship** points shall be forfeited for that whole Event, irrespective of the timing of the offence committed at that Event. Where a “double header” Event takes place at the same Venue over a weekend and is conducted as two separate Race days then this regulation shall only apply to each day individually.

Grid Position – after a Penalty whereby a Driver receives a driving or technical Penalty that Driver will start from the pit lane for the remaining Races in which **they** competes during the Event therefore not gaining an advantage.

Additionally any Driver penalised with the imposition of licence penalty points (**NCR Chapter 2 App.12**) will have Championship points deducted (even if this results in a minus total) on the following scale;

2 licence penalty points = 50 Championship point deduction

3 licence penalty points = 100 Championship point deduction

4 licence penalty points = 200 Championship point deduction

6 licence penalty points = 300 Championship point deduction

## DRIVING STANDARDS

In the event of a Registered Competitor's driving standards falling below the standards considered to be appropriate to the Championship, the Championship Co-ordinator (or the Deputy), and/or Clerk of the Course will consider any incident or occurrence. As a result of their consideration if (a) a breach of driving standards and/or (b) behaviour either on or off the Track such as to bring the Club or the **Championship** into disrepute and/or (c) any other breach of these Regulations, the **Stewards** may take any action as prescribed in the **NCR**. In addition to any such action, the Championship Co-ordinator may issue a Championship 'Yellow Card' warning to any Competitor for action or driving deemed to be detrimental to other participants and/or the interests of the Championship.

If a Competitor is issued with a 'Yellow Card' they will be placed under observation by the Clerk of the Course at the following two Events in which they take part. If any Competitor receives **two or** more 'Yellow Cards' that Competitor may be subject to any of the following:

(a) Suspension of Racing Membership of the KMSC thus making the Competitor ineligible for the Championship under **Art.** 1.3.2. The period of the suspension will be notified to the Competitor in writing and may cover one or more subsequent **Events / Races** of the Championship.

(b) Be required to satisfactorily complete a course specially devised by the KMSC in conjunction with the KMSC Motorsport UK qualified Driver Coaches. The course will be at the Competitor's expense.

'Yellow Cards' are cumulative and are cancelled at the end of the season.

Social Media – Social media, including, but not restricted to, Facebook, Instagram, Twitter etc. is a powerful and wide reaching medium for the expression of views and opinions, and the sharing of photographs and video. As such, Competitors should be aware that their conduct on social media regarding the Championship, Knockhill Racing Circuit, the KMSC and its Drivers should reflect the impact social media has. If a Competitor is considered to have brought the Championship, Knockhill Racing Circuit and/or the KMSC into disrepute in the opinion of the Championship Stewards they may be subject to a Penalty or Disqualification from the Championship. Additionally, Competitors are reminded that the **ASN** monitor social media and any remarks that are deemed to bring the sport into disrepute can lead to penalties and referral to the **ASN Disciplinary Officer who may refer the matter to the ASN National Court.**



## 5. TECHNICAL REGULATIONS:

### 5.1 INTRODUCTION:

The following Technical Regulations are set out in accordance with the **ASN** specified format and it should be clearly understood that if the following texts do not clearly specify that you can do it you **must** work on the principle that you cannot. No Legends Cars parts supplied by the Organiser or their approved suppliers may be modified in any way without written permission from the **Championship Eligibility Scrutineer**, which will be communicated to all registered Competitors by means of a Technical Bulletin (**Official Document**). Competitors registering or racing in the Championship **are** deemed to have full knowledge of these Regulations, and to have accepted the same in full.

The Organiser reserves the right to place identification labels/markings on controlled parts to ensure these parts have been purchased through 600 Racing / Handy Distribution or the Organiser's approved supplier; existing controlled parts on Cars and any spares held by Drivers or Teams may also be labelled/marked. Once parts have been labelled/marked any unlabelled/unmarked parts **on a Car presented for the Competition** will be deemed to be **ineligible**. All labels and security stickers must remain in original form – do not paint over. Controlled parts **must** carry a security sticker and are listed in Appendix 6.5. All new & controlled parts on this list **fitted to a Car** must carry a 600 Racing security sticker. It is the responsibility of the Driver to make sure security stickers are in place.

### 5.2 GENERAL DESCRIPTION:

The Scottish Legends Cars Championship is for Competitors participating in a Legends Racing Car supplied by 600 Racing or a 600 Racing authorised dealer. Cars under second or subsequent ownership **are** eligible providing **that** they were first supplied by 600 Racing or an authorised dealer. **These Cars are** eligible for other Events in the UK and Europe providing that the Event has been officially sanctioned for Legend Cars by 600 Racing and they conform to that Championship's **and or Event Regulations**. The Organiser reserves the right to request that the Eligibility Scrutineer carry out spot checks at any time during a Race **Event**. The spot check can include the removal, and temporary substitution by the Organisers/600 Racing, of **any** part for **examination and or** testing. **The removal of any part is** subject only to the fact that such spot checks by themselves shall not affect the Driver's / Entrant's ability to take part in the Races **at the Event**.

The Eligibility Scrutineer can **require** a Competitor to submit their engine, gearbox, complete Car or part thereof for stripping, examination or testing at a nominated time and location decided by the Eligibility Scrutineer. The parts may be sealed until the examination **and the relevant sealing certificate(s) are Official Documents**. **The relevant parts** may be either:

- a) Given direct to a specialist (if present at the track) for inspection at the nominated time.
- b) Retained by the Eligibility Scrutineer for inspection at the nominated time.
- c) Have the component transported (at the Competitor's cost) to the specialist by the nominated time with the seals intact.

The Competitor can be present whilst the Eligibility Scrutineer carries out the examination. The Car or any parts thereof **(duly sealed as above)** may be removed or retained for further testing or examination.

The Organiser reserves the right to use any engine builder as the nominated specialist provided that it not another Championship Competitor or in any way associated with another Championship Competitor's Entry. This specialist will provide any assistance necessary for the Eligibility Scrutineer to carry out the checks. Prior to the engine(s) inspection and after examination by the Eligibility Scrutineer the carburettors may be retained by the Competitor. The Competitor may change the ignition timing & camshaft timing (if applicable) under the supervision of the Eligibility Scrutineer. Any item or items found to be ineligible will need to be replaced with eligible parts before a Competitor competes in further Races. The cost of such work will be met by the Competitor / Entrant.

## 5.2.1 Examination of Cars:

### Technical Checking

- a) The Championship Eligibility Scrutineer / Championship Organiser reserves the right, to inspect, test, measure, seal or impound any component or liquid (including fuel) fitted to or used in conjunction with any Car registered in the Championship either personally or through a nominated representative. Any cost associated with scrutineering or eligibility inspections (including but not limited to transportation, checks, inspections, rebuilds etc) will be the sole responsibility of the Entrant / Driver.
- b) Entrants must at all times comply with the directives of the Eligibility Scrutineer and the Championship Organiser in respect of scrutineering and eligibility checking.
- c) Any component sealed by an ASN Official must remain sealed and may not be tampered with in any way. In the event of a seal needing to be broken for repair or replacement, prior to doing so the Eligibility Scrutineer must be informed in writing and approve the seal being broken. Re-sealing will take place after technical checks have been made at the next Race Event, or by an authorised engine builder.
- d) All components and parts on the Car that are deemed relevant to safety performance and eligibility of the Car may be required to carry Championship seals.
- e) All Championship seals fitted to a Car and its relevant parts will be recorded by the Eligibility Scrutineer and that record is an Official Document.
- f) Queries concerning eligibility should be referred in writing to the Championship Eligibility Scrutineer at least seven days prior to an Event Entered to permit a ruling in advance of any Event at which it is intended to compete. Electronic communication is an acceptable format for this purpose.
- g) Tests to establish the power output of any Car may be carried out by the Organiser or their representatives. Such power testing will be used using a rolling dynamometer equipment which must have a current Certificate of conformity and which shall be an Official Document together with the results of such testing.
- h) Components on Competitor's Cars may be verified by comparison with the similar components sourced from official 600 Racing parts.

The Organiser (in addition to any other powers they may have under these Regulations) reserve the right before or after any Race in the Championship to designate any one or more of the competing Cars for special eligibility scrutineering. Upon such designation being made the Competitor shall immediately place the Car under the control of the Organiser and is deemed to have permitted all such scrutineering, examination and testing as the Organiser may responsibly require to undertake. The Organiser has the right to have present any other specialist(s) of their choosing and:

Examine the Car at the Circuit for such period as they may reasonably require and take fuel samples **(NCR Chapter 8)** and/or:

Retain the Car for detailed examination at premises chosen by the Organiser. If the Organiser elects to retain the Car they shall make it available for collection by the Competitor at least **3 (three) clear** days prior to the Qualification session for the next Race in the Championship unless the Car is found to be in breach of these Regulations and/or:

Seal the Car and its components in **accordance with the NCR (the sealing record is an Official Document)**, and require the Competitor at their own expense to present the Car at any premises chosen by the Organiser for detailed examination within a specified period **in accordance with the NCR** and/or remove the Car by transporter at no expense to the Competitor to an appointed location. The Competitor will be advised in writing **(an Official Document)** of the time, date and location of the subsequent testing or eligibility examination **and has the right to be present**.

The overseen stripping of the engine or any required component will be undertaken by the Competitor and/or mechanic/technician nominated by the Competitor. The Organiser reserves the right to re-inspect **Cars** at any time during the course of the **Championship** should there have been a regulation infringement or Circuit Incident.

Competitors **are** personally and solely responsible for ensuring that their Cars comply with their **Championship** Registration details and with these Regulations for each Event **in** which they are Entered. Failure to comply in either respect will be a breach of these Regulations **and may be subject to Penalty (subject to the rights of Appeal – NCR Chapter 2)**.

Queries concerning eligibility should be referred in writing to the Organiser **via the Championship Coordinator** / Eligibility Scrutineer at least seven days prior to an Event Entered **so as** to permit a ruling in advance of any **Event** at which it is intended to compete.

### 5.3 SAFETY REQUIREMENTS:

**NCR Chapter 7 & 9** apply:

**ROPS: Motorsport UK Chapter 7 App.3 Art.1-85 & Art.91-93**

Additionally:

- a) Protective padding must be applied and securely fixed to those parts of the roll cage with which the Driver's body or helmet could come into contact.
- b) Towing points at the front and rear must be fixed to the front and rear frame rail, and must be indicated by yellow paint (or a clearly visible contrasting colour) and marked with the word 'Tow'. Towing eyes must be of suitable strength and attached to the Car fit for the purpose of towing, any injury or accident resulting from the failure of a towing point will be the responsibility of the Driver / Entrant. Towing eyes **must** not protrude beyond the ends of the chassis frame rails.
- c) Additional doorplates and door striking plates must be fitted. (See Appendix 6.5 Technical Drawing for detail).
- d) Door release bolts must be fitted horizontally on the inside of the doors in a centre position (as originally fitted on import from the USA). This applies to both 'suicide' and normal opening doors. The release bolt handle must be painted in neon paint in contrast to the inside door colour and a sticker (supplied by 600 Racing) must be applied to the exterior of the doors to indicate the position of the release bolt. It is highly recommended that two or three spot welds are added to the centre section of the door hinge to prevent it unfolding in an **Incident**.

- e) A plumbed in fire extinguisher system must be fitted and must conform to **NCR Chapter 7 App.6**. Fire extinguishers must be an FIA homologated standard Fire Extinguisher Systems in Competition Cars (1999) or FIA Standard 8865-2015 and be serviced by the manufacturer or their agent within the preceding 24 months.
- f) The **ASN waiver CTE-2024-053** for Legends Cars against **NCR Chapter 7 App.2 Art.14 & 77** applies.
- g) Helmet and Racewear (**NCR Chapter 9. Minimum standards as detailed in Chapter 12 App.12 Art.6**) applies throughout any Competition, Practice or Event.
- h) There must be external triggering / activation points for the fire system and the electrical circuit breaker (**NCR Chapter 7 App.5 Art.13-18**). These must both be located on the front windscreen scuttle panel (**NCR Chapter 7 App.6 Art.14**), preferably to the right and clearly marked with the appropriate **ASN** symbols.

## 5.4 GENERAL TECHNICAL REQUIREMENTS & EXCEPTIONS:

5.4.1 At the start of each Event, Practice or Race each Car will be presented in a manner that **benefits** the **Championship**. The Organiser reserves the right not to issue the relevant paperwork to allow a Car to be scrutineered if it is **deemed** not to be of an acceptable standard of preparation. **Cars must be** presentation **in** a neat, clean and 'stock' appearance of a Legends Car, with any previous crash damage having been fully repaired.

These Technical Regulations **are based on** the 2000 Official rulebook together with the modifications required and approved by the Organiser / 600 Racing for Competition in **the UK and** Europe. Any INEX rule changes or modifications since publication of the 2000 rulebook, unless encompassed in these Regulations, are **of no effect** and not permitted unless the Organiser / 600 Racing give written Notice to all Competitors **and which Notice is an Official Document**.

Legends Cars are designed to Race in their standard/stock form only; this includes all aspects of their appearance (excluding paintwork & decals). Only those adjustments and additions specifically permitted under these Regulations are allowed, otherwise any other changes will **render the Car ineligible**.

All custom-made parts for Legends Cars, including body panels, must be obtained from 600 Racing, a 600 Racing authorised dealer or the Organiser's approved supplier. Non-custom parts are free within the control limits of these Regulations. Legends Cars have **an ASN** waiver under the provisions of **NCR Chapter 7 App.2 Art.14 & 77**.

5.4.2 Prior to competing in **this** Scottish Legend Cars Championship the **Car** must undergo a Safety Scrutineering inspection which will be undertaken by the KMSC Chief Scrutineer, Championship Eligibility Scrutineer or their appointed deputies, unless the **Car** competed in the same condition in the **preceding year** Championship. Additionally all **Cars** must undergo a Safety Scrutineering inspection at least every 4 Events. Any **Car** involved in **a contact Incident**, or having been modified in any way, **must** be represented to the Scrutineers for further examination (**NCR Chapter 7 App.12 Art.5**) **unless notified to the contrary by a Championship or Event Official**. A record of inspections will be maintained by the Championship Organisers **and which are Official Documents**. The Event Organiser may select Cars for pre-Event safety inspections, the method of selection and times/locations for inspection will be notified in the Event **Official Documents**.

## 5.5 CHASSIS:

5.5.1 FRAME/CHASSIS: All Cars and frames running as Legends Cars must be produced and purchased through 600 Racing and must carry the serial number assigned to the Car. The serial (VIN) number can be found on the Legends number plate on the chassis. This plate **must** be clearly visible at all times and not tampered with in any way. The Car owner must be able to produce the title documents and/or proof of purchase or sanction to Race from 600 Racing within 48 hours of an Official request. Unless this documentation can be produced 600 Racing/the Organisers can prohibit the Cars from racing.

Gussets: Strengthening gussets may only be added in the spots described in Appendix 6.5 Technical Diagrams. No stock gussets may be removed. Additional strengthening of the pickup point on the frame for the 6½" rear axle upper radius rod is permitted with some freedom **provided that** any additional gusset or tube must be similar in dimensions and thickness to those around this pick-up point. The bolt may only pass through the original pick-up point currently supplied by 600 Racing Europe, pick-up point thread and no other (apart from a lock nut if so desired).

A mandatory 'Left Side' bar in the rear must be added to every Legends Cars frame (both coupes and sedans). The material used for this bar is (1" x 1½" x 0.120" wall or its nearest equivalent). The length for the sedan is 14¾" and the coupe is 13½" (with an angle at one end). The distance this bar **must** be from the B-Pillar (See Appendix 6.5 for diagram) is 25".

Part number LC1059 Front clip brace 20mm square box 2.5mm thick and length between 200 & 275mm may be installed under side rear of front clip.

(It is highly recommended to have the frame checked by an expert for metal fatigue every 12 months or following a major incident). Any Legends Car Chassis over four years old must be stripped and examined by an expert to ensure that it is fit for the purpose of racing, a copy of the report **must** accompany the Car at all times. Cracked or broken frames are strictly prohibited from any 600 Racing/KMSC Event.

'Suicide' doors are only permitted on 600 Racing factory OEM frames, no changing of the original door hinging positions is allowed. The chassis cannot be modified or altered in any way, apart from the modifications allowed in these regulations or for any reason from the stock chassis supplied by 600 Racing.

5.5.1.1 Two side roof braces must be added to every Car (other than coupes). The additional supports are shown in Appendix 6.5 (Drawing 10.2) Technical Diagrams of these Regulations.

5.5.2 FRAME/CHASSIS REPLACEMENT: Should the chassis become severely damaged, replacements must be purchased through 600 Racing/the Organisers authorised dealer. The Competitor must give the damaged chassis including VIN plate to 600 Racing for disposal before a new chassis will be released to the Competitor, the replacement VIN plate will then be approved.

5.5.3 FRAME/CHASSIS REPAIR: Front and rear clips only may be replaced as long as they are replaced with the exact material that it is replacing and all pickup points must remain in stock locations as delivered currently from 600 Racing. The clips must be purchased from 600 Racing/the Organisers approved supplier. The Drivers compartment of the frame, (roll bars, cross braces etc) may not be repaired or replaced if damaged or altered in any way. The Eligibility Scrutineer reserves the right

to disallow a repaired Car which does not appear to have been properly repaired.

- 5.5.4 **BOLTS and FASTENERS:** Only the equivalent stock or upgraded steel fasteners and bolts may be used on the Legends Car. Fasteners may be drilled for safety (maximum wire hole size 3mm) wire but intentional weight saving modifications are not permitted. Aluminium and titanium or other lightweight fasteners are **ineligible**. Bolts secured in their standard or currently supplied positions with 'Nyloc' nuts (i.e. steering rack, shock absorbers, panhard rod, seat belts, engine bolts, track rods, rod ends and others) must be secured using a full depth 'Nyloc' not a half nut, and two clear bolt threads must show past the nylon lock.
- 5.5.5 **FIREWALL:** A metal firewall is mandatory. A removable inspection plate is permitted in the firewall, but it must be totally sealed whilst the Car is on Track.
- 5.5.6 **PICK-UP POINTS:** Absolutely no modifications of the frame, pick-up points or spindles will be permitted unless referred to in these Regulations or advised by 600 Racing/the Organiser in writing to all Competitors **and which shall be an Official Document**. Only one pick-up point for the panhard bar on the frame is permitted in the standard location. Damaged or bent spindle(s) and or pick-up points must be repaired by the beginning of the next Race. Only one  $\frac{3}{4}$ " mild steel spacer is allowed and this is to be fitted in it's original intended position between the rear axle panhard rod and the axle casing pick-up point. All other spacers will be either  $\frac{1}{4}$ " or  $\frac{1}{2}$ " and of mild steel material.
- 5.5.7 **WHEELBASE:** All Cars must comply with a minimum 73" + or –  $\frac{1}{4}$  inch no tolerance outside these dimensions. To facilitate this wheelbase the rear panhard rod may be connected to either side of the Right Hand chassis pick-up point.  
Measuring wheelbase: The measurement will be taken with the front and rear tyres on one side in line with each other. To determine this, the measuring tool straight edge, or line must touch three points. These points are the front of the rear tyre sidewall and the front and the rear of the front tyre sidewalls. The measurement is then taken from the front edge of the front wheel rim to the front edge of the rear wheel rim. The process is the same when measuring wheelbase on the opposite side of the Car. Should a wheel rim be in such condition that it would not give an accurate measurement, the Competitor will be requested to change wheels for a suitable rim so the measurement can be taken.
- 5.5.8 **WIDTH/HEIGHT/OFFSET:** The total overall width of the Car front and rear may not exceed 60 inches. The Car must be able to roll freely through a 60" wide gauge. The Official gauge is fitted with a 60" 'trigger' bar, which must be capable of retaining it's position within the gauge while the Car is being pushed through.  
All Cars must be under a maximum of 48" in overall height.  
  
There must be a minimum of 6" between the inside edge of the rear brake drum and the rear frame rails. No wheel or axle spacers are permitted.  
The maximum camber (negative or positive) on either front wheel of a Legends Car that will be permitted to Race or Practice with is 4 (four) degrees.
- 5.6 **BODYWORK:**
- 5.6.1 **AERODYNAMICS:** Spoilers, air dams or any other aerodynamic devices are not permitted.

- 5.6.2 **BUMPERS:** The front and rear bumpers must remain the standard dimensions, steel thickness, location and configurations as supplied by 600 Racing / the Organiser's approved supplier. They must be securely fastened as supplied in original form (using the captive nut on the tabs).  
One additional bolt per frame rail may be added to secure the tab.  
**BUMPERS, BOTH FRONT AND REAR MUST HAVE TWO ADDITIONAL SECURING DEVICES - SAFETY WIRE LOOPS **MUST** BE USED AT **EACH** END OF EACH BUMPER.**  
At the start of each Practice or Race straight undamaged bumpers (front and rear) will only be allowed to compete with un-repaired straight tabs of the maximum dimensions of mild flat steel material. The distance from the end of the chassis rails to the rear of bumper uprights (both front & rear) will be no less than the Official tab gauge which measures approx 25mm (but the gauge will be the Official gauge). See Appendix 6.5 for bumper dimensions.  
**IF A BUMPER (FRONT OR REAR) BECOMES DISLODGED WHILST ON TRACK THE COMPETITOR MUST ENTER PIT LANE FOR THE BUMPER TO BE RE ATTACHED (TO THE SATISFACTION OF THE SCRUTINEER) OR A REPLACEMENT BUMPER BE FITTED. IT IS NOT PERMITTED TO RE JOIN THE TRACK WITHOUT A BUMPER.**
- 5.6.3 **CHROME PLATING/POLISHING:** Parts such as bumpers, nerf bars, wheel rims and valve cam covers may be chrome plated or polished. Suspension parts may be nickel, zinc or similarly plated.
- 5.6.4 **DOOR PLATES:** A doorplate on the Driver's side door, and striker plates on both doors are mandatory. (See Appendix 6.5 Technical Drawings). The door plate is optional for the Right-Hand side door, and a Competitor may use a door plate to cover the complete door area on either side of the Car as long as it is only 1/8" thick.
- 5.6.5 **FENDER WING MOUNTING:** Stock fender/wing mounts may not be altered from the original (ie moving the inside of the fender/wing away from the grill). No additional mounts are permitted, the closest mounting holes to the grill must be used. Removal of the fibreglass on the body half under the rear wings is **mandatory** as it substantially aids safety checks of the rear axle pick-up points, chassis and other components.
- 5.6.6 **FENDER/WING HOLES & TRIMMING:** A maximum of seven holes in each of the front wings for air circulation and cooling of the engine are permitted, **no part** of these holes may exceed 4". The outside edge of the front wings and the bottom of the front wings may not be trimmed. The inside vertical edge of the left-hand wing (exhaust side) may not be trimmed. The inside edge of the right-hand wing (carburettor side) may only be trimmed to allow the 600 Racing/the Organiser's approved and supplied one piece air filter to fit with minimum clearance. No holes are permitted in the rear wings or body shell apart from the trimming to allow for the exhaust silencer to clear the L/H rear wing, this to be kept as close to the exhaust system as practical. The outer edge of the rear wing may be trimmed for additional tyre clearance, but the wing contour must measure at least 10" from the main body shell. Measurements will be taken from a point on either rear wing above top dead centre of the tyre. The original standard position of wings to the body shell & frame must remain as supplied on each model.
- 5.6.7 **FIBREGLASS COMPONENTS:** All fibreglass body components must be purchased from 600 Racing or an authorised dealer/the Organiser's approved supplier and must carry the authorised decal of 600 Racing/the Organiser, and may not be reinforced or intentionally lightened in any way with the exception of **Art. 5.6.6**. These components must be securely attached to all Cars. Any Car failing in this regard may be Disqualified from the Event.

All body parts must remain in their standard location as supplied by 600 Racing. The grill, front wings and bonnet/hood must be of the same model.

- 5.6.8 GENERAL APPEARANCE of the CAR: All Competitors must present a neat, clean and stock appearing Car for any 600/the Organiser's Competition. Crash damaged cars must be repaired to the minimum technical standards and approved by the Eligibility Scrutineer or deputy before returning to Competition. The Eligibility Scrutineer or deputy may deny a Car from Competing if it does not meet the minimum acceptable standards as mentioned above, and **that** decision will be final. **This Decision must be recorded as an Official Document and managed as an Eligibility Decision under these Regulations and the NCR.**
- 5.6.9 GRILL: The steel grill must remain within the stock dimensions, steel thickness, location and configurations delivered by 600 racing/the Organiser's approved supplier and may not be reinforced in any way. The grill must be the same model as the hood, grill shell & front fenders that are used. The grill mountings must not be modified.
- 5.6.10 HOOD/BONNET: Any bonnet hole(s) or louvers must be on the Left Side (Cylinder Side) of the bonnet, which means no hole(s) or louvers may be on the Right Side (Carburettor Side), over a line drawn from the centre of the front bonnet pin to a point which is the centre of the rear of the bonnet. Bonnet Louvers are defined as aluminium plates with maximum 3/8" edges. The size of the area for holes will be 1 x 4 inch diameter maximum or 3 x 2 inch diameter maximum holes in the hood. It is not permitted to run with the rear of the bonnet raised.
- 5.6.11 MIRRORS: All Cars must have an interior rear-view mirror with a minimum area of 6". One pair of external mirrors must be mounted outside the doors, but each external mirror must not exceed a maximum of 10sq. inches area, and secured with a maximum of two fittings (i.e. two nuts and bolts, two pop rivets, two machine screws etc).
- 5.6.12 RUNNING BOARDS: The running boards must remain within the stock dimensions, steel thickness, location and configurations as supplied by 600 Racing / the Organiser's approved supplier and may not be re-enforced in any way. The Left-Hand support bar has to be modified to allow the UK exhaust system to pass. The tubing of the rear two chassis mounting brackets can be cut back to allow the exhaust to pass with a nominal clearance and then must have a flat plate/bar welded to cover the cut tubing, bent to pass under the exhaust pipe and re-connected to the original chassis position with the currently supplied bolts and washers. The metal plate/bar used to re-connect the tube back to the chassis, will be the same steel dimensions and thickness as the flat bar/plate in the part as currently supplied. (See Appendix 6.5 Diagrams).
- 5.6.13 SHEET METAL: The minimum thickness of sheet metal is .036". The rear deck (parcel shelf) shall be modified to remove the gaps between the bodywork & roll cage to provide a firewall between the Driver's compartment and the fuel cell. In carrying out this modification the parcel shelf must not be moved from it's original position, no part of the modifications to the shelf will show above the lower edge of the side and rear window apertures. A fuel cell access hole is not permitted. The legends dashboard as Legends stock component as supplied by 600 Racing including the new fibreglass Pod-Dash & other than those as stated in **Art.** 5.10.4.
- 5.6.14 SEATS: Only 600 Racing/the Organiser's approved FIA seats may be used. In altering the seat position for safety and comfort the front seat mounting brackets (two of) may be modified. The modified mountings must still be welded to the floor seat mounting rail (this rail position cannot be changed). If the seat mountings are longer



that the originals then they should be suitably reinforced, or made of heavier material in proportion to their length. The rear seat mountings cannot be altered.

5.6.15 WINDSHIELDS: As a waiver of **NCR Chapter 7 App.2 Art.77** it is recommended a mesh screen be used for safety reasons or a Lexan windshield is permitted in the front window only. The maximum dimension of the rear window is 23" x 8 1/8" with a tolerance of 1/8".

## 5.7 ENGINE:

5.7.1 Should any Competitor Race with an engine that has not been registered with the Eligibility Scrutineer the Competitor will have a 200 **Championship** point deduction for that **Event** and will run off the back of the grid for the remainder of that Event. Competitors are allowed **four (4)** engines for the **current Championship**, or 1 engine and **3** rebuilds, or 2 engines and **2** rebuild for the **current Championship**. Either 1250, 1200 or 850 may be used. Effectively this is **4** sets of engine seals. Engines must be sealed by the Championship Eligibility Scrutineer before use (as detailed in 5.7.2). The seal identification marks will be recorded **(as an Official Document)** and used to monitor the rebuild or replacement of the engines. The breaking of any seal will indicate that the engine has been rebuilt or replaced. The exception is that any minor repairs or adjustments may be carried out under the direct supervision of the Eligibility Scrutineer or a nominated deputy. Engine seals can only be broken with the prior approval of the Championship Eligibility Scrutineer. Any seals broken without prior approval will **render** the engine to be non-compliant. All engines must be registered with the **Organiser via the** Eligibility Scrutineer before being used in the Championship.

Should more than **4 (four)** engines, or rebuilds as above be used in the **current Championship** the Competitor will run off the back of the grid for the next 2 Races, even if it be at the next **Event**. This will apply to each engine, or rebuild over **4 (four)**. This **Regulation** will also apply to Team Cars. Should any Competitor Race with an engine that has not been registered with the Eligibility Scrutineer the Competitor or Team Car will have a 200 **Championship** point deduction for that **Race** and will run off the back of the grid for the remainder of that Event.

5.7.2 GENERAL ENGINE SPECIFICATION RULES: The engine must remain a factory-stock Yamaha FJ1200/XJR1200/XJR1250 (sealed) as supplied by 600 Racing (UK)/the Organiser's approved supplier. Only those changes as described in these Regulations are permitted to be made to the 1200's only. The Yamaha FZ09/MT09 **(sealed) three cylinder water cooled** engine may also be used **and must remain** in stock configuration **as supplied by 600 Racing(UK)/the Organiser's approved supplier Derek Hales Limited**. **No other engines are permitted. Use of salvage engines is not permitted.** Remote oil filter is NOT permitted on the Yamaha FZ09/MT09 engine. The FZ09/MT09 crankcase breather must remain in its Stock location. All engines (1250, 1200) must **always have** the four central and two rear (nearest to the bulkhead) head nuts drilled for possible sealing by the Eligibility Scrutineer. Two holes must be drilled in each of the six nuts as close as to the top of the domed part of the nuts as possible. The location of the sealing points on the FZ09/MT09 will be informed by bulletin issued by the Eligibility Scrutineer **as an Official Document**. The holes must be 2mm or larger. An additional seal will be attached by the Eligibility Scrutineer **and which shall be recorded as an Official Document**. This seal must remain in place at all times; should there be a need to check shims or cams this can only be done under supervision of **an ASN** Licensed Scrutineer. Gear boxes must be sealed to the engine using two adjacent bolts, drilled with holes to 2mm or larger, in the vicinity of the oil

filter. All sealing points must be clearly identified by contrasting colour paint. **The Seals shall be recorded on an Official Document.**

5.7.3 Cranking Compression: All Engines. (see **Art.** 5.7.14)  
Aftermarket gaskets are permitted.

5.7.4 XJ1250 Sealed Engine Specifications:

1200 Cylinder Heads can be used on 1250 engines but **MUST** have the same cc as 1250 engines **and be sealed in accordance with Art. 5.7.2.**

Procedure for emergency repairs to sealed engines at race meetings:-

The Eligibility Scrutineer or his nominee must be informed and be present before any seals are disturbed / broken / cut.

It is at the Eligibility Scrutineer's discretion if any repairs may be carried out. The Scrutineer **or his nominee** must remove the seals required **and remain present** to oversee the repairs.

As parts are removed they are to be marked (with scrutinising paint or tagged with a seal to ensure correct /same parts are refitted), once fitted seal / paint may be removed.

In the event of a replacement part being required, eg. Camshaft , this is to be marked and the Eligibility Scrutineer will list all new parts fitted to be referred to the approved / Official engine builder for later inspection on re-sealing **and this mandatory record shall be an Official Document.**

Any engine builders seal removed will be held by the Eligibility Scrutineer and will be replaced with an **ASN** seal which may be used for the remainder of the Championship. The engine may need to be re – inspected by the Official / approved engine builder prior to the next **Event**, and officially resealed **and recorded as an Official Document.** The cost of inspection, rebuilding and sealing to be paid by the Competitor.

If on inspection by the Scrutineer a discrepancy is found, all **Championship** points scored with this engine with temporary seals will be forfeited plus an additional 200 **Championship** points penalty.

All results will remain provisional until the engine has been declared legal.

The 1250 engine must remain sealed and may not be restored to a 1200 engine (the 1250 engine will have a serial number with P501E/P502E/P503E/P506E/P508E/P515E engine number prefix.

The only modifications permitted to be made to the factory sealed 1250 engine are:-

- A. Changing the carburettor jets (changing the main jets, idle jets and air corrector jets is allowed, changing the piston spring and metering needle is also allowed).
- B. All stock carburettor adjusters may be used.
- C. Adjusting the valve shims.
- D. Installing an aftermarket clutch and spring of original design or twin plating the original spring plate. (No aluminium clutch plates are allowed).
- E. Upper head oilers, heavy duty valve springs, and "Pinned" Camshafts are permitted only if installed by an authorized engine builder. It is permissible to return the oil from the oil cooler to any part of the engine.

- F. Steel liners and Wiseco (Legends Edition) Pistons are permitted as supplied by 600 Racing.
- G. A water-cooled Cylinder Conversion may be used by means of parts as supplied by 600 Racing. This conversion must be fitted by a 600 Racing/the Organiser's authorised engine builder.
- H. Oil pressure relief valve may be shimmed to increase oil pressure.

Apart from items A to H above and the fitting of any aftermarket connecting rod bolts **ABSOLUTELY NOTHING CAN BE IMPROVED ON THE ENGINE** – this includes machining any component to a better tolerance than supplied as OEM.

NOTE TO APPROVED XJR1250 ENGINE REBUILDER(S):

All permitted modifications to the FJ1200/XJR1200 are strictly **not permitted** on the XJR1250 (sealed). The objective of the approved engine rebuilder(s) is to repair or maintain the XJR1250 (sealed) in its' absolute 'stock' OEM condition. This will mean that no oversize pistons are allowed and therefore once a sleeve is worn or damaged it must be replaced with the standard size Yamaha part, or 600 Racing supplied Wiseco 0.004 or 0.008 inches oversized pistons. Any rebuilt or repaired XJR1250 (sealed) that is found to have a performance advantage over a 'stock' engine of this type may lead to the approval of the engine builder being withdrawn by 600 Racing/the Organiser and a 12 month ban to the Competitor entering 600 Racing / KMSC Events.

- 5.7.4.1 Only Camshaft Yamaha part No 5EA-12171-00 (inlet) and 5EA-12181-00 (exhaust) are allowed. Both cam timing dots must be visible in cam cap window at TDC. The only camshaft timing wheels permitted are for the carburettor specification camshaft, cam wheels from injection shafts are not allowed.
- 5.7.4.2 No slotting, oversize drilling of cam gear boltholes, only cam bolts part no. 90105-6424 may be used.  
Camshaft lobe dimensions  
Intake A 35.950-36.050 mm Limit 35.850 mm  
Intake B 28.058-28.158 mm  
Exhaust A 35.950-36.050 Limit 35.850 mm  
Exhaust B 28.045-28.145 mm:  
Degree Manufacturers Tolerance
 

0	8.04	8.04
5	7.95	7.99
10	7.69	7.87
15	7.40	7.61
30	5.79	6.05
45	3.40	3.64
60	0.66	0.84
75	0.20	0.26
90	0.05	0.09
105	0	0
- 5.7.4.3 Cylinder deck to piston heights must be a minimum of 0.013 thou, cylinder height 3.475 inches, together with Standard Yamaha steel base gasket part no 5EA-11351-00 (0.010 thou thickness gasket) will give the required piston to deck clearance. Bore and Stroke, 79.0 x 63.8 mm displacement 1251 cm3.
- 5.7.4.4 Only standard Yamaha pistons Part no 5EA-11351-00 or legends edition Wiseco pistons up to 0.008 thou oversize are permitted.

- 5.7.4.5 Only standard Yamaha or Wiseco piston rings may be used. No Total Seal piston rings are allowed.
- 5.7.4.6 The only permitted machining of the valve seats angles are;-75-60-45-15, 70-60-45-30, 60-45-30, 60-45-15. The seat width min 0.030 thou.  
 Valve head dia (intake) 28.90-29.10mm, (exhaust) 24.90-25.10 mm  
 Valve face width (intake) 1.980-2.550 mm, (exhaust) 1.980-2.550 mm  
 Valve seat width (intake) 0.90-1.10 mm, (exhaust) 0.90-1.10 mm  
 Valve stem dia (intake) 5.475-5.490 mm, Limit 5.445 mm  
 Valve stem dia (exhaust) 5.460-5.475 mm, Limit 5.430 mm  
 Valve guide inside dia (intake) 5.500-5.512, Limit 5.552 mm  
 Valve guide inside dia (exhaust) 5.500-5.512 mm, Limit 5.552 mm  
 Valve stem to valve guide clearance (intake) 0.010-0.037 mm, Limit 0.080 mm  
 Valve stem to valve guide clearance (exhaust) 0.025-0.052 mm, Limit 0.100 mm  
 Valve stem runout 0.010 mm
- 5.7.4.7 No enlarging of the seat inside throat diameter.
- 5.7.4.8 Valve face angle must be 45 degrees, No back cutting, the vale must remain standard, Yamaha part no36y- 12111-00 and 36y-12121-00.
- 5.7.4.9 Heavy duty valve springs or valve Spring shims can be used to take the same amount of space that has been cut away if the valve seats and valve faces have been cut, with a max installed pressure 68 psi.
- 5.7.4.10 Only XJ series heads may be used. (No FJ series heads).
- 5.7.4.11 Cylinder head resurfacing is allowed, but additional Base gaskets will be required to ensure that a compression ratio of 10:1 is not exceeded.
- 5.7.4.12 Cylinder head CC in standard form is 33.2cc to 34.2cc any variance below this will require additional gaskets be fitted.
- 5.7.4.13 Internal components cannot be polished **or** Bead blasted **or** Shot peened.
- 5.7.4.14 All other components to be stock Yamaha parts.
- 5.7.4.15 An alternative to heavy duty cylinder head studs is permitted by way of an "inverted top hat" insert and non-stock cylinder head nut.
- 5.7.4.16 The stock I.D.at the bottom 1/16 (one sixteenth) of the valve seat insert is 0.990" for the intake port and 0.830" for the exhaust port. No port alterations of the intake or exhaust below the seat are permitted.
- 5.7.4.17 CAMSHAFTS: (1200cc engine only)  
 The cam shaft (one intake and one exhaust) must remain as stock Yamaha FJ1200/XJR1200 as and in the same location supplied by 600 Racing / the Organiser's approved supplier. The camshaft marking 'I' (Intake) and 'E' (Exhaust) may not be removed, and must remain in their appropriate positions. Stress relieving by machining or polishing on the radius next to the cam gear or on the shaft is permitted (see Appendix 6.5 for drawing). Modifying any part of the lobes (lift, profile, duration, weight etc.) is **not permitted**. Aftermarket overhead oiling systems for the camshafts are permitted. Steel billet intake cams are not permitted. Installation of a ¼" ID x ½" OD piece of 4130 aircraft steel the full length of the camshaft is permitted.  
 Note: This modification must be carried out in a very specific manner, Please contact

600 Racing for details.

#### 5.7.5 FJ & XJ 1200 Engine Specifications:

Unless otherwise specifically stated within these regulations only the original stock components supplied & intended for FJ & XJ 1200 engines are allowed.

Carburettors:

Changing the carburettor jets is allowed.

All stock carburettor adjusters may be used.

Changing the main jets, idle jets and air corrector jets is allowed.

Changing the piston spring and metering needle is allowed.

The emulsion tube cannot be modified in any way and must remain as standard.

Material cannot be removed from any part of the carburettor body or piston.

Aftermarket gaskets are permitted.

The above apply to all 1200 and 1250 engine carburettors.

5.7.6 AIR FILTERS: Only 600 Racing/or the Organiser's approved air filters and outer wear pre-filter coverings are permitted. Air filters may not have an element more than 3" in height (bottom of filter element to top). Velocity/ram stacks are not permitted. No air filters that direct air flow to the carburettors or increase air flow are permitted (including those with moulded ram stacks). The air filter element must not contain, either inside or outside, any heat shields or air deflectors of any description. No additional items are permitted within the air filter other than the element itself. The use of ram pipes is prohibited. Air filters constructed with fibreglass parts are not permitted.

5.7.7 CAM CHAIN: The cam chain must remain as stock Yamaha FJ1200/XJR1200 as supplied by 600 Racing/the Organiser's approved supplier.

5.7.8 CAM CHAIN ADJUSTERS: Aftermarket manual cam chain adjusters are permitted.

5.7.9 CARBURETTORS: The carburettors, float bowls and emulsion tubes must remain as stock Yamaha FJ1200/XJR1200/(XJR1250 sealed) as supplied by 600 Racing/the Organiser's approved supplier. Only carburettor jets and needles may be replaced and only stock adjusters used. No other modifications to the carburettors or float bowls are permitted. Modifications or components to increase or restrict airflow to the carburettors (such as velocity stacks, heat deflector shields, internal modifications not listed above) are not permitted. Only the OEM heat shield between the carburettors and engine is permitted and may not be altered in any way.

Plastic topped carburettors are not permitted

The inlet rubbers must have the marking 36Y on the component and may not be altered in any way.

Throttle inlet diameter maximum 36mm and may not be machined or polished or altered in any way.

Choke diameter maximum 29mm and may not be machined, polished or altered in any way.

The Carburettor piston may not be altered in any way, and the diaphragm hole must not exceed 4mm.

The Diaphragm must not be altered from manufacturer's specification.

5.7.10 CLUTCH: The clutch (plates and springs) may be replaced with any aftermarket type of the same design (no aluminium or titanium clutch plates). Twin plating the original spring diaphragm plate is permitted (and recommended).

- 5.7.11 **CYLINDER HEAD:** The original cylinder head must remain in unaltered 'as cast' condition **except for** of machining the head gasket surface. Valve seat inserts may be reworked or replaced with OEM or aftermarket seats of original dimensions. The stock ID at the bottom of the 1/16" (one sixteenth) is 0.990" for the intake port and 0.830" for the exhaust port. No port alterations of the intake or the exhaust below the seat are permitted. O-ringing the head gasket seal area is not permitted. The combustion chamber may be matched and cc balanced to the highest cc chamber, which has been unaltered. Relief cuts for cc balancing may not exceed the bore size.
- A combustion chamber may be repaired by welding and grinding back to the official 'stock' configuration of the combustion chamber. An alternative to heavy duty cylinder head studs is permitted by way of an "inverted top hat" insert and non-stock cylinder head nut.  
(not permitted for World Final INEX Events).
- 5.7.12 **COMPRESSION RATIO:** The compression ratio may not exceed 10.00:1 (no tolerance). Only the following may be done to meet this rule:- machining the piston domes, machining the gasket surfaces of the cylinder head and/or cylinder casings.
- 5.7.13 **CRANK SHAFT:** The crank shaft must remain stock FJ1200/XJR1200 as supplied by 600 Racing/the Organiser's approved supplier. Modifying the throw balances or weight of the crank is illegal; minimum weight 27lbs. One throw on the crank must have no balancing holes in it.
- 5.7.14 **CRANKING COMPRESSION:** The cranking compression testing method is with all spark plugs removed, with throttle fully open and engine to be cranked between 10 and 12 revolutions to determine the cranking compression value. Cranking compression value must not exceed 165 lbs/sq in for 1200 engines and 180 lbs/sq inch for 1250 engines on any of the cylinders. On the 1200 engine the cam timing may be adjusted accordingly to meet the requirements of this rule by slotting the cam sprocket gear or substituting with an aftermarket cam gear sprocket (this is not permitted on the 1250 sealed engine). There is no tolerance for 1200 engines over 165 lbs/sq in. (It is recommended that engines are set below the maximum to allow for variances of heat). The Scrutineer may request a change of battery should the engine not turn over sufficiently.
- 5.7.15 **ENGINE COATINGS:** Only the coatings a supplied stock from the factory are permitted throughout the engine. Intentional removal of any coatings is not permitted. Exhaust manifold pipes may be painted with high heat paint only and they may also be wrapped in manifold heat tape.
- 5.7.16 **ENGINE COOLING:** An extra fan(s) internal duct work as approved by 600 Racing, remote oil filter, header wrap, and oil cooler is permitted, oil coolers must comply with these regulations - see Oil Cooler Section (**Art.** 5.7.21).
- 5.7.17 **ENGINE SERIAL NUMBERS:** All engine casings must have a YAMAHA serial number. An additional engine seal will be attached by the Eligibility Scrutineer that must remain in place at all times, Any engine casing without a serial number will be **ineligible** and not be permitted to be used in any 600 Racing/KMSC Events.

- 5.7.18 **ENGINE LOCATIONS & MOUNTS:** The engine and upper and lower engine mounts must remain within the stock dimensions, steel thickness (no aluminium mounts), location and configurations as currently supplied by 600 Racing/the Organiser's approved supplier. The right side of the engine may be fitted with an additional aftermarket steel mounting no more than 4½" wide; no mounts may be welded to the frame rails apart from the two Right-Side factory fitted lugs. If the optional Right Side mount is used the original mounting lugs/brackets on this side may be removed. No engine mounts can be angled or altered in any way.
- 5.7.19 **OIL ADDITIVES:** The following additives in the engine oil are not permitted:- hydrazine, toluene, dinitrotoluene, dioxane, propylene oxide or nitropropane.
- 5.7.20 **OIL CATCH CANS:** An oil catch can (minimum 500ml maximum 1000ml capacity) must be used. It must be securely fastened and remain within the engine compartment. It may only be routed to by a hose from the stock crankcase breather opening, or the oil fill cap.
- 5.7.21 **OIL AND WATER COOLERS & LINES:** Oil coolers must be cooled by air only (no dry ice systems or other type). All oil & water cooling systems (including lines) must be mounted in the engine compartment only. No oil coolers or lines may be mounted in the Drivers compartment or in or on the rear deck or fuel cell compartment. More than one oil cooler is permitted. Oil cooler fans are permitted. Ductwork behind the oil cooler to direct hot air away from the engine is permitted; this ductwork must not protrude below or outside the frame rails. Push-lock fittings are permitted. Oil coolers may not be mounted below the bottom of the front bumper; all oil coolers must be securely mounted on mild steel mounting rails or plates and drilled only for fasteners or outlets for oil lines. Oil cooler air scoops are permitted (with a maximum of 1/8" sheet metal (aluminium permitted)) but must be kept completely within the frame rails and must not project lower than the front bumper.
- 5.7.22 **OIL CRANKCASE BREATHERS:** The only place that the crankcase may have a breather is a) under the carburetors at the stock outlet or b) from the oil filler cap.
- 5.7.23 **OIL FILTERS, REMOTE:** Remote oil filters are permitted and must be mounted in the engine compartment only. Inside or outside mounting of the remote oil filter to the frame rail is permitted. The remote oil filter must be located in a position where it cannot be easily damaged in the event of an **Incident**. Remote oil filters may not be mounted below the bottom of the front bumper.
- 5.7.24 **OIL PUMP:** The stock oil pump may not be modified in any way. Relief valves may be shimmed. Sump baffle may be installed.
- 5.7.25 **PISTONS & RINGS:** The cylinder bore may not exceed 77.57mm or 3.054" (maximum .022" overbore from stock). Only Yamaha pistons (Part No 1TX 11631-00 and 1TX 11636-00) or forged Wiseco Pistons (Part No K1188, L1195, L1199 and L1202) may be used. Only Yamaha rings (Part No 1TX 11610-00 and 1TX 11610-20) or Wiseco Rings (Part No 21-3041X9 and 21-3051X6) may be used. These rings may not be altered in any way. The ring lances and lower part (skirts) of the piston may not be altered from the original in any way. Gas-porting the pistons are not permitted. Worn cylinder sleeves may be replaced with aftermarket sleeves. Wrist/Gudgeon pin buttons may be used.

- 5.7.26 **RODS (CONNECTING):** The rods must remain in stock for the FJ1200/XJR1200 delivered by 600 Racing/the Organiser's approved supplier. Rod bolts may be changed to any aftermarket type. Only shotpeening the rods is permitted (no polishing by any means is permitted). Weight balancing to the lightest unaltered rod is permitted. All dimensions must be stock. XJ1250/1300 connecting rods are not allowed.
- 5.7.27 **STROKE:** The stroke must remain stock for the FJ1200/XJR1200 63.8mm.
- 5.7.28 **VALVES:** Only Yamaha FJ1200/XJR1200 valves are permitted. No modifications are permitted to the valves with the exception of altering the number of angles of the seat and a maximum backcut width up to 0.200" is permitted from the edge of the valve. Valve jobs are permitted. Only stock valve lifter and adjuster shims may be used.
- 5.7.29 **VALVE GUIDES:** The valve guides must remain the same size, length and location (see Appendix 6.5 for drawing). The guides may not be altered in any way. Shotpeening of valve guides is not permitted. Brass aftermarket valve guides of the same dimension of stock may be used.
- 5.7.30 **VALVE SPRINGS:** The valve springs may be replaced with aftermarket steel springs. Only stock steel valve spring retainers and clips/keepers are permitted. No titanium or other lightweight alloys are permitted.
- 5.8 **SUSPENSION:**
- 5.8.1 **BALL JOINTS:** The upper and lower ball joint must remain stock, within the stock dimensions, steel thickness location and configurations as supplied by 600 Racing and may not be reinforced in any way. For the purpose of checking dimensions the Eligibility Scrutineer may select a ball joint from 600 Racing supplied parts and compare the dimensions against the similar component on the Competitor's Car. One or two (Minimum ¼" – Maximum 7/16" width) jam nuts are permitted on the upper and lower ball joints. Each ball joint must use at least one jam nut. The jam nuts may not be welded to any component. Additional Split pins or R Clips are acceptable as nut locking devices.
- 5.8.2 **HEIM ENDS/ROD ENDS:** Only steel rod ends as supplied by 600 Racing or of the same dimensions are permitted on a Legends Car. The stock rod ends are designed to bend/break and absorb energy under impact and the Competitor accepts the responsibility and risk of upgrading rod ends. Rod ends may be upgraded, but aluminium, titanium or other lightweight rod ends are not permitted.
- 5.8.3 **JAM NUTS:** At least one jam nut is required to be used with all rod ends, clevis ends and ball joints. One or two (Minimum ¼" – Maximum 7/16" width) jam nuts are permitted on the upper and lower ball joints. Split Pin or R Clip in addition are acceptable.
- 5.8.4 **LOWER CONTROL ARMS:** The lower control arms must remain stock, within the dimensions (12½" x 16¼"), steel thickness, location and configuration delivered by 600 Racing (UK)/the Organiser's and may not be altered in any way. Each measurement will have a tolerance of +/- 1/8" (0.125").



- 5.8.5 RADIUS RODS/PANHARD BAR: The radius rods and panhard bar must remain stock dimensions (radius rods – either 6½”, 11” or 12” in length - panhard bar 23½” in length), aluminium thickness, location and configurations of the original, supplied by 600 Racing. Each measurement will have a tolerance of +/- 1/8” (0.125”). Steel radius rods or panhard bars are not permitted. The 11” and 12” rods may be interchanged anywhere on the Car as long as the Car still meets all other specifications contained within [these Technical Regulations](#).
- 5.8.6 REAR AXLES (HALF SHAFTS): The long and short rear axles must remain two piece, within the stock dimensions, steel thickness, location and configurations as supplied by 600 Racing/the Organiser’s approved supplier, and may not be altered or reinforced in any way. The outer face of the half shaft, or shaft modified for lightening purposes or axle casings not in accordance with the rules are not permitted. New one-piece axles supplied by 600 Racing must carry the INEX logo. Shaft dimensions as per drawing in Appendix 6.5.
- 5.8.7 RIDE HEIGHT: Restricting the rear axle movement in any way other than the ‘stock’ components is not permitted. The Car may have no less than 3 ½ inches between the bottom of the frame rails and the level ground. This measurement will be taken without the Driver in the Car. The Eligibility Scrutineer or deputy will designate a location where ride height checks will be carried out.
- 5.8.8 SHOCKS: All Legends Cars Carrera Shocks #3363 or #3363R or Bilstein (gas pressure single setting). The Bilstein shocks are stamped with the INEX logo and can only be as supplied by 600 Racing/the Organiser’s approved supplier. Shock Numbers or INEX marks and / or silver security stickers must be [always](#) visible. Changing or altering the fluid inside is illegal. Shocks may be turned upside down and or the upper part of the rear shock may be mounted on either side of the inside or outside of the frame. Shock bumpers are permitted.
- 5.8.9 SPINDLES/FRONT STUB AXLE: The spindles (and pick-up points) must remain stock, with the stock dimension, steel thickness, location and configurations as supplied by 600 Racing. The new approved aluminium spindle supplied by 600 Racing must be installed by using the larger ball joint and upper arm; the spindle arm as supplied by 600 Racing must have the INEX logo visible on top at all times. Damaged or bent spindles and pick-up points must be fixed by the beginning of the next Race and with prior approval from the Eligibility Scrutineer. Additional gussets, strengthening (including over welding) is not permitted.
- 5.8.10 SPRINGS: All Legends Cars must use a 10” or smaller length spring. Any spring weight combination and aftermarket springs are acceptable. Only one spring is permitted per shock. Spring rubbers are not permitted.
- 5.8.11 UPPER CONTROL ARMS: The upper control arms must remain stock, within the stock dimensions (4¼ ” in length) steel thickness, location and configurations supplied by 600 Racing and may not be altered in any way. The tolerance on the measurement will be +/- 1/8” (0.125”).
- 5.9 **TRANSMISSION:**
- 5.9.1 GEAR RATIOS: The differential gear ratio permitted is a 2.93 for Yamaha 1200/1250 [and FX09/MT09](#) engine Cars, FZ09/MT09 engine Cars only [may also use](#) a 3.33:1 [and 3:42:1 differential gear ratio](#) at all 600 Racing/KMSC Races. The gears must remain within the stock dimensions, steel thickness, location and configurations as supplied by 600 Racing/the Organiser’s approved supplier. The use of any other gear

ratio is not permitted.

1st 40/14 (2.857)

2nd 36/18 (2.000)

3rd 33/21 (1.571)

4th 31/24 (1.292)

5th 29/26 (1.115)

Primary reduction ratio 98/56 (1.750)

Secondary reduction 39/18 (2.167)

- 5.9.2 CLUTCH OPERATION: Rubber or steel-braided clutch lines are permitted. The master and slave cylinder must remain stock, (Yamaha part number SEA 16381-00) in their original positions and configurations. The clutch pedal may be 'cranked' over to give greater Driver leg comfort, but only in conjunction with removal of the left side brake pedal. No needle bearing upgrades allowed.
- 5.9.3 DRIVE SHAFT/PROP. SHAFT: The drive shaft, flanges and u-joints must remain within the stock dimensions, steel thickness, location and configurations as supplied by 600 Racing. Lightening the drive shaft in any way is illegal. A 600 Racing approved drive shaft retainer strap is permitted. A maximum of three retainer straps of ¼" thickness and ¾" width are permitted.
- 5.9.4 REAR ENDS/DIFFERENTIALS/AXLE CASINGS: Only the 10 bolt pattern 5/8" wide flange Toyota, locked steel rear ends are permitted. All rear end components and pick-up points must meet the specifications of the original stock components as when the Legends Car was supplied 'New' with 0 camber +/- 1 degree tolerance (scrutineer check after Practice, before Race one). Double Shear housings are permitted, see Appendix 6.5 Technical Diagrams. The rear end must be locked (all spider gears welded or a steel spool of a minimum 6.0 lbs (six pounds) weight as supplied by 600 Racing/the Organiser's approved supplier only). No limited slip differentials, aftermarket differentials, quick change rear ends, floaters, homemade or otherwise, are permitted. Only OEM bearings are permitted. No hemispheric or similar type bearings are permitted. No spacers are permitted between the backing plate and bearings. The planet gear pin may be cut out to improve the removal of broken half shafts, the pin ends and all the planet gears must remain in place unless a spool is being used.  
Gussets and modifications permitted on the rear axle – see Appendix 6.5 Technical Diagrams of these regulations; these are the only additional gussets allowed on rear axles, all pick-up points are to remain in the same dimensions, steel thickness and configurations supplied by 600 Racing.
- 5.9.5 SPROCKET ADAPTORS: The sprocket adaptors must remain stock, within the stock dimensions, steel thickness, location and configurations of the original, as supplied by 600 Racing/the Organiser's approved supplier. Set screws for the sprocket adapter nut are permitted. Sprocket adaptor/propshaft bolts may be drilled for security wiring. Lightening the sprocket adaptor for weight savings in any way is illegal.
- 5.9.6 TRANSMISSIONS & GEARSHIFT MECHANISM: The transmission and transmission gears must remain stock Yamaha FR1200/XJR1200/XJR1250(sealed) as supplied by 600 Racing/the Organiser's approved supplier. They may not be lightened in any way. The transmission gears may be shimmed only for the purpose of proper engagement. Standard and aftermarket shims may be used. The gear shift mechanism must remain as a "stock" part and in original position / location and configuration supplied by 600 Racing. Needle bearings are not allowed.

The gear shift lever and link rod must be as per the 'stock' part. The aluminium clamped lever on the splined shaft from the engine may be changed for the steel splined Yamaha part supplied by 600 Racing and modified for length. The 'Triangle' may have a welded boss/bush added to minimise play in this component. Needle bearings are not allowed

Reverse Gears: All Legends Cars must be fitted with a reverse gear that is in operational order at all times. Only a 600 Racing supplied reverse box (or a box from the Organiser's approved supplier) with a mechanism running a one to one forward drive is acceptable; no other system is allowed. **No Paddle Shift or Quaife reverse boxes are permitted.** The original location, metal thickness, dimensions, configurations and ratio of all components and parts supplied with the mechanism cannot be altered in any way; any weight saving measures on these components will be considered illegal. Eligibility Scrutineering will apply and component sealing will take place. Only 600 Racing upper and lower brackets can be used for installation of the reverse system.

## 5.10 **ELECTRICS:**

5.10.1 **IGNITION & WIRING SYSTEM:** The complete ignition/engine control system must be the original OEM parts for Yamaha FJ1200/XJR1200. The stock ignition control box (black box) must remain in its original position as supplied by 600 Racing/the Organiser's approved supplier on the front bulk head engine side on the right hand side as viewed by the Driver. A 600 Racing approved ignition control box and ignition plate is permitted, neither of these ignitions can be modified or tampered with in any way, the RPM limiter must be **always** in proper working order and must remain unmodified and not tampered with in any way. Only one ignition box per Car is allowed. The wiring harness should be the standard factory production part number LC155X00X001 supplied by 600 Racing with the quick fit connectors to allow easier engine removal are permitted; only in-line fuses are permitted (no fuse blocks). All wiring must be in visible connections (no junction boxes).

Electronic throttle controls (traction) are not permitted.

Coils, Coil Wires and Spark Plug Boots: These components must be stock Yamaha FJ1200/XR1200/XR1250 (sealed) parts as supplied by 600 Racing/the Organiser's approved supplier. The spark plugs and boots may be replaced with any aftermarket type with similar thread size; resistors must remain in the spark plug boots. The FJ1200/XJR1200 coils and leads may be replaced with 'Dyna 2.2  $\Omega$ ' from a 600 Racing/Organiser approved supplier.

The 'stock' coil mount must remain in its currently supplied position by 600 Racing. The ignition plate may be slotted to advance the timing on the FJ1200/XJR1200 only. No aftermarket electronic ignition advances are permitted.

600 Racing/the Organiser reserves the right to provide a substitute ignition/engine control system to any Competitor at random at any time. The 600 Racing/Organiser approved system will be exchanged for the Competitors system and must be used for that Event. 600 Racing/the Organiser is not responsible for any failure of the component(s) supplied.

Re-positioning of the ignition, starter, choke, gear position indicator & rear light switches only to a small panel on the inside of the right side door is permitted. Or projecting them from the standard Legends dashboard position by no more than 4 inches maximum, and by means of a simple sheet metal fabrication only. This is to assist those Drivers having difficulty reaching the dashboard whilst strapped in. A 600 Racing supplied f/glass dash pod only is available and approved.

Rain Lights: All Cars must be fitted with a FIA specification, rear facing red warning(s). They must be external mounted in a vertical plane at the rear of the Car and comply with [NCR Chapter 7 App.5 Art.19-22](#). It must be illuminated when requested by the Clerk of the Course or other Official.

No forward facing lights of any description are allowed.

5.10.2 ALTERNATORS: Modification to the charging system is not permitted. The alternator must be charging at all times. No switches disconnecting the alternator are permitted.

5.10.3 BATTERY: Only the 'stock' battery or one of similar dimensions (7 1/8" x 8" x 6 1/2" approx) and weight to the stock battery may be used. A top post or side post battery may be used. Motorcycle batteries may not be used. The battery must remain in its stock location on the rear bulkhead and securely mounted. The original stock battery bracket may not be altered in any way. (See drawing Appendix 6.5 measurement 5 1/2 inches from chassis rail).

5.10.4 GAUGES: The only gauges permitted are ones that record the following:- engine rpm, exhaust gas temperature, lap timer, oil pressure and oil temperature. Gear change lights are also permitted. [FZ09/MT09 engined Cars are permitted to install the AiM Legends Mxm Dash SKU: MXM-LEGEND-X87MXM0007.](#)

GPS is not allowed, and data cannot be downloaded to a lap top or any similar device. The only other timing information allowed will be by means of the bulletins issued by the official Championship timing company.

5.10.5 RADIOS: The use of individual Competitors' one- or two-way radio systems at any time for any reason is prohibited. Radio wiring looms are not permitted within a Legends Car at any Race for any reason. Only [an ASN](#) approved one-way RACECEIVER system must be installed, which is under the control of the Clerk of the Course.

5.10.6 TRACTION CONTROL DEVICES: No electronic or computerised wheel spin/traction control device(s) are permitted. [After market quickshifter or paddle shift gear change is not permitted.](#)

## 5.11 BRAKES:

5.11.1 Any of the brake parts that are attached to the rear axle or the spindles (front stub axles) must remain stock, within the stock dimensions, steel thickness, location and configurations as supplied by 600 Racing. The Car must have operational brakes on all four wheels and must lock up all four wheels during inspections (Brake lines may not be plugged or completely shut off). Any type of cooling duct to the brakes is prohibited. The right or left side brake pedal may be removed.

Any brake pads or shoes are permitted. Steel brake lines/'cupro nickel lines' may be substituted for steel-braided brake lines and re-routed to give greater protection. No rubber or copper brake lines are permitted.

The new Wilwood brake system may also be used when Officially approved, supplied by 600 Racing and must carry the INEX logo. Approval will be notified by technical bulletin [as an Official Document](#).

Brake Rotors/Brake Discs: Only steel discs (not drilled or reduced in diameter) are permitted on the front. The minimum permitted thickness of the disc is 8mm wide.

**Brake Drums:** Only drums (not drilled or lightened) are permitted on the rear, as supplied by 600 Racing. The minimum weight of the brake drum is 10.0lbs (ten pounds). Intentional metal removal of the brake drum for lightening purposes is illegal.

**Brake Master Cylinder:** The brake master cylinder must remain stock, within the stock dimensions, location and configurations as supplied by 600 Racing/the Organiser's approved supplier. The brake master cylinder must remain on the engine side of the firewall. Only aftermarket master cylinders to the exact dimensions and configurations supplied by 600 Racing are permitted.

**Brake Proportion Valves:** Any number of aftermarket brake proportion valves for the brakes are permitted, but complete elimination of the brake at any wheel is prohibited.

## 5.12 **WHEELS / STEERING:**

5.12.1 **WHEELS:** Only 600 Racing/the Organiser's approved supplier supplied steel wheels that have a 13" diameter, a 7" width and the offset of only 2<sup>3</sup>/<sub>4</sub>" to within a +/- variance of 1/8" (2 5/8" to 2 7/8") is permitted. The minimum weight of a tyre and wheel must be at least 12.2 kg without additional steel, lead or wheel weights. All wheel weights must be the 'Stick on self adhesive type' only and be covered with duct or metal tape. Wheel weights must be external and not added inside the tyre. Bleeder or relief valves are not permitted in the wheels. Should a new wheel be introduced it must carry the INEX logo and be supplied by 600 Racing / the Organiser's approved supplier.

5.12.2 **RACK and PINION STEERING:**  
Only the rack and pinion steering box as supplied and stamped '600 Racing' or 'Mid-State Machine' is permitted. Any other marked or unmarked steering box is not permitted. Two additional gussets are permitted to the steering rack mounting plate (See Appendix 6.5 – Technical Diagrams). New improved part available from 600 Racing 1/4inch thick plate.

5.12.3 **BUMP STEER:** Adjustments for bump steer settings will only be permitted by placing spacers above or below the track rod ends. No other modifications to change bump steer is permitted (i.e. altering position of steering rack or pick-up points on the spindles).

5.12.4 **STEERING COLUMN:** The steering column may be modified for Driver comfort or safety; the universal joints may be upgraded and the final bearing (on the dash panel support bar) and its' position can be changed. The steering column bearing and its' stock or 600 Racing needle bearing bush in the lower firewall, must remain in its stock and currently supplied position. No shortening of threads is permitted if a rod end(s) type bearing(s) is/are used. Changing the spline in the steering rack is not permitted. A hose clamp is mandatory on the steering column in the engine compartment directly against the firewall (see Appendix 6.5). The Scrutineers decision will be final on the safety of any upgraded or standard steering linkage. No steering quickeners are permitted, without special written permission from 600 Racing. The European collapsible column is acceptable supplied by 600 Racing.

5.12.5 **STEERING WHEELS:** Custom steering wheels are permitted, the scrutineers decision on their safety will be final; all steering wheels have to be on steel quick release hubs.

## 5.13 TYRES:

5.13.1 The tyre must be the Organisers approved 205/60R13 **Nankang Econex NA-1** Tyre. Tyres may not be soaked, softened, siped (razor cuts), grooved or re-capped (remoulded). No tyre at any time will be softer than 58 points on the durometer. Tyre warmers and any other means of artificially warming tyres are prohibited. At all times during an Event the tread depth must not be less than 1.6 mm over at least 125mm of the tread width pattern. It is prohibited to use traction compounds or any substance that might alter the physical properties of a tyre as supplied by the manufacturer. Tyre cleaners and shiners, tyre softeners, track adhesives, brake fluid, diesel fuel, etc will not be permitted on tyres. The use of tyre heating/heat retention devices, tyre treatments and compounds is prohibited.

## 5.14 WEIGHTS:

- 5.14.1 The minimum weight is 610 kgs (Yamaha 1200/1250 engine), and **590kgs** (FZ09/MT09 engine) when weighed with the Driver and in full racing condition after any Practice or Race. The Eligibility Scrutineer will designate the scales to be used for any post-Race checks and they will be deemed to be the Championship scales. **The scales must have a current Certificate of Conformity and which is an Official Document.**
- 5.14.2 **WEIGHT SAVING MEASURES:** Lightening of 'Stock' components by shaving, milling, drilling or any other method is illegal. Any item on a Legends Car that is used (other than what is mentioned in the rules) as a weight saving method is considered illegal. All non-stock aluminium, titanium, stainless steel components are considered illegal.
- 5.14.3 **BALLAST:** A maximum of eight blocks of lead are permitted. The blocks may be no larger than 12" x 1.5" x 2.5" which will weigh no more than 20 lbs and the stacking of blocks is illegal. Two blocks of lead may not be in contact with each other. All lead must be clearly visible with neon paint or tape wrapping and marked with the Car number. Ballast may not be added by any other method, including steel shot or any other material in frame rails, bumpers, nerf bars or any other component. Blocks must be directly bolted through the oblong frame rails only using two 3/8" or equivalent bolts & lock nuts; blocks or any ballast may not be placed anywhere inside the Drivers compartment. The Scrutineer's decision will be final on the safe mounting of ballast blocks. The provisions of **NCR Chapter 7 App.2 Art.63-65** refers as a minimum.

## 5.15 FUEL TANK/FUEL:

- 5.15.1 **FUEL:** Only unleaded fuel to BSEN228 or BS7800 as defined in the **NCR Chapter 8 App.1** is permitted, i.e. as available from roadside filling stations. The Eligibility Scrutineer may require any Competitor to exchange fuel with any other Competitor or to use fuel to the above specifications supplied by the Eligibility Scrutineer. When available, fuel testing will be carried out. A minimum of 3 litres of fuel must be present at the end of any Practice or Race for fuel sampling purposes. The Organiser reserves the right to introduce a control fuel which will be publicised by Competitor bulletin during the **Championship and is an Official Document.**
- 5.15.2 **FUEL ADDITIVES:** No additives are permitted **except that the Championship Organiser reserves the right to select a fuel additive to lower emissions (the use of 'RemNOx' fuel additive is recommended to lower emissions).**

5.15.3 FUEL CELL: Any INEX approved Fuel cell (plastic or metal) as supplied by 600 Racing/the Organiser's approved supplier must be used in its stock form & location – foam is mandatory in all Fuel cells as supplied by 600 Racing/the Organiser's approved supplier (Cars are not permitted on Track without the foam in place). Fuel cell cap gaskets must be in place and kept in good condition. The stock as originally supplied method of holding the Fuel cell line in place cannot be modified in any way. Fuel cooling devices are not permitted.

Any plastic Fuel cell will be fitted with a underside stone guard (This can be aluminium). This additional plate (stone guard) as tank protection is mandatory.

Fuel **is** not to be stored below ambient temperature in the Car. All Fuel cell caps must be clearly marked with the Car's Race number. Large plastic cap Fuel tanks are not permitted.

5.15.4 FUEL FILTER: Aftermarket Fuel filters may be used. Glass Fuel filters **are not** permitted.

5.15.5 FUEL LINES and PUMP: Fuel lines must not be routed through the Driver's compartment; all Fuel lines must be flexible steel braided pipe or cupro nickel pipe, suitably mounted to prevent chafing. Only one 'stock' fuel pump as supplied by 600 Racing/the Organiser's approved supplier is permitted (LC955X00X013) The ID of the Fuel pipe must remain the same as the original supplied by 600 Racing Fuel pipe. Fuel lines may not be attached to or routed with any electrical wires. The Fuel pump must be the standard pump OEM as supplied by 600 Racing/the Organiser's approved supplier (A 3psi pump only).

5.15.6 FUEL SHUT-OFF VALVE/FUEL REGULATOR: Aftermarket Fuel shut-off valves and Fuel regulators are permitted.

## 5.16 **SILENCING:**

5.16.1 EXHAUST SYSTEM: - A 'stock' system only is permitted. The header (manifold pipes), collector, down pipe and silencer box must be as supplied by 600 Racing. The internal and external components of any of the stock exhaust system pipes or silencer (LC1009, 1010, 1012, LC105X00X501 (1)(2)(3)(4) cannot be altered in any way. Header wrapping tape is permitted. The silencer must be the current production and supplied by 600 Racing. The only official permitted collector will be the current part supplied by 600 Racing which will be stamped with 600 Racing identification ( LC105X00X521) or a substitute part supplied by Derek Hales Ltd. Due to the dimensions of the exit pipe, it is a requirement that the pipe to the silencer is inserted inside the collector exit. The collector exit may be "slotted" to allow a gas tight joint.

The provisions of **NCR Chapter 7 App.8 Art.1-8** apply.

Collector Position – the centre of the weld of the collector (where the four manifold pipes go into one chamber) shall be positioned between 40mm and 100mm forward of the firewall bulkhead.

Maximum OD of any manifold pipe is 38.5mm **(1200 & 1250cc engines).**

Silencer as approved and supplied by 600 Racing only.

Stainless steel pipes, silencer, and manifold as supplied by 600 Racing/the Organiser's approved supplier are permitted

5.16.2 MUFFLING/ EXHAUST SILENCING: Silencing will be in accordance with **NCR Chapter 7 App.8 Art.9-27**. Measurement will be made at 0.5m from the end of the exhaust pipe with a microphone at an angle of 45 degrees with a maximum permitted level of 108db.

5.17 **NUMBERS and CHAMPIONSHIP DECALS:**

5.17.1 All Cars must be identified by numbers complying with **NCR Chapter 7 App.10** displayed in a position acceptable to the Timekeepers.

5.17.2 The following are reserved area requirements for Championship Decals:

**MAIN CHAMPIONSHIP SPONSOR:** As a minimum the area immediately above the windscreen (18" x 6") 46 x 15 cm is reserved.

**OTHER SPONSOR:** Lower rear of back wing on both sides (decal measuring 15 sq. inches maximum).

**SUBSIDIARY CHAMPIONSHIP SPONSOR:** A space for one decal on both sides of the car for each subsidiary sponsor (decals each measuring 20sq. inches maximum and not exceeding 6" in length).

**LEGENDS CAR LOGO:** A space for one 5½" or 15 cm (min) logo on either side of the car in front of the rear wheel arch and immediately above the rear wheel arch line and immediately above the rear nerf bars uprights.

**ON THE DRIVERS RACE SUIT: MAIN CHAMPIONSHIP SPONSOR:** A patch not exceeding 8 sq. inches, on the upper chest immediately below the neck line.

**OTHER SPONSOR:** (If different from the main Championship sponsor) A patch not exceeding 8 sq. inches on the upper chest immediately below the neck line, second only in prominence to that of the main Championship sponsor.

**LEGENDS CARS:** A patch not exceeding 8 sq. inches on the upper front body.

5.17.3 The Organiser will supply Championship Decals but number decals are the responsibility of the Registered Driver.



## 6. APPENDICES:

### 6.1 RACE ORGANISING CLUBS & CONTACTS:

General enquiries: Andrew Donald  
Scottish Legends Racing, Knockhill Racing Circuit, Nr. Dunfermline, Fife, KY12 9TF  
Tel. 07701 055605  
E-mail. andrewdonald44@gmail.com

Eligibility Scrutineer (for technical enquiries): **Gordon Hay**  
Tel. **07740 243100**  
E-mail. **gordonehay@hotmail.co.uk**

**Derek Hales Limited**  
**9 School Road, Foulden, Norfolk, IP25 5AA**  
**Tel. 01366 328272**  
**E-mail. derek@derekhales.co.uk**

600 Racing – Phil Cooper  
600 Racing (UK) Ltd., PO Box 209, Cranleigh, Surrey, GU6 8PT  
Tel. 07983 596607  
E-mail. phil.600@btinternet.com

Transponders – SMART Timing  
E-mail. sharp@compuserve.com

### 6.2 COMMERCIAL UNDERTAKINGS:

The following Commercial Undertakings are not subject to the Judicial procedures of either the Championship Stewards and/or **the ASN NCR**.

6.2.1 Enquiries concerning the commercial aspects of the series should be addressed to the Championship Co-ordinator.

The Championship title and associated logo styles may only be used with prior written approval of the Organiser.

Competitors are advised that, unless requested otherwise, their information will be stored in a computer retrieval system and may be used for publicity purposes.

Entry into the Championship is conditional upon each Competitor:

- i) Providing free of charge to the Organiser advertising places on their Cars and clothing as specified.
- ii) Accepting without reservation or recourse the surrender of **their** rights (if any) for TV filming and broadcast of footage collated during the Championship, which may be used at the Championship Organiser's, Sponsor's and Promoter's discretion.
- iii) Complying with the Organiser's and Sponsor's requirements on podium procedures, including a requirement to wear Championship Sponsors' publicity material in preference to the Competitor's own sponsor.
- iv) Co-operating with requests for publicity sessions throughout the **Championship**.

- 6.2.2 The use of the Legends Cars trademark is reserved for Competition Legend Cars, Drivers and mechanics overalls and competition **Cars** only. The trademark may not be used on any items offered for sale or used outside of the applications outlined above without the express written permission of 600 Racing.
- 6.2.3 Space will be allocated to Competitors by the Organiser within the area provided for Legends Cars by the **Event Organiser**. The area provided to each Competitor will be in accordance with a layout plan published in advance of the **Event** by the Organiser **as an Official Document** or as directed by the Organiser on the day. All Legends Cars must park and be kept in this area when not racing and should not be taken elsewhere to be displayed or worked upon without the permission of the Official in charge of the Legends paddock area. No other Cars are permitted in the Legends Cars paddock area. Failure to adhere to this condition may result in the withholding of points and **Awards**.
- 6.3 **TRADE SUPPORT **CAR** DECALS & OVERALL PATCHES:**
- 6.3.1 Trade Support **Car** Decals & Overall Patches – No colour restrictions are applied. Competitors are encouraged to produce imaginative and distinctive colour schemes that will add to the spectacle of Legends Cars racing so long as these are well maintained and Cars presented at Race circuits to a standard acceptable to 600 Racing/the Organiser.
- 6.3.2 Competitors may display any sponsors names, graphics or trademarks except those that are of companies, organisations or products in competition to the main or subsidiary sponsors of the Championship which shall not be displayed on the Car in any manner.
- 6.3.3 The display of the Competitors own graphics, sponsors names or trademarks must be within the reasonable boundaries of good taste for which 600 Racing/the Organiser will be the final arbiter. The display of tobacco advertising on anything associated with Legends Cars is prohibited. **No display may be offensive.**
- 6.3.4 **By Registering for the Championship** Competitors **are** deemed to have undertaken responsibility for the display of the obligatory Championship Decals, outlined in **Art. 5.17**. Failure to comply with these requirements may lead to ineligibility and consequences under Section 4 of these Championship Regulations.
- 6.4 **PROMOTIONAL ACTIVITIES:**
- 6.4.1 No tobacco (or associated product) advertising, either on the Car or Driver is permitted. Additionally, any products that are not permitted to be advertised on UK terrestrial television are also prohibited.
- No advertising or statement on the Car or on the Drivers' Race clothing is allowed which may be considered offensive to the Organisers, the Promoters or their Sponsors.
- All Drivers required for Podium Presentations at each **Event**, **must** attend without delay. Failure to do so may mean forfeiture of any Championship Awards / points at the **Race or Event**.

**PARTS LIST:**

All parts **must** carry a 600 Racing silver security sticker at all times.

They **must** carry a security sticker when being replaced.

It is envisaged that it will be mandatory for all these parts to carry a security sticker.

LC1012	Exhaust Can	LC120A11A020	Fender Left Front 37 White
LC1014	Reverse Gear Box	LC120A20A000	Body 37 Chevy Sedan Right
LC1022	Reverse Gearbox Bracket Top	LC120A21A020	Fender Right Front 37 Chevy White
LC1022A	Reverse Gearbox Bracket Bottom	LC120B01A040	Hood 37 Ford White
LC1056	Mocal Oil Cooler	LC120B10A000	Body 37 Ford SD Left White
LC1057	Fibreglass Dash	LC120B11A020	Fender Left Front 37 Ford White
LC105X00X100	Air Duct Ignition Coil Mount	LC120B12A020	Fender Left Rear White
LC105X00X104	Bumper Air Scoop F/Glass	LC120B20A000	Body 37 Ford SD Right White
LC105X00X105	Fender Scoop Air Duct F/Glass	LC120B21A020	Fender Right Front 37 Ford
LC105X00X110	Engine Air Duct Lower Alum Chevy	LC120B22A020	Fender Right Rear White
LC105X00X206	Right Side Motor Mount	LC120C02A010	Deck Lid 37 Chevy
LC105X00X207	AZ-D Left Side Motor Mount	LC120E00A000	Body 34 Ford CP Comp White
LC105X00X208	Ignition Coil Mounting Plate	LC120E01A030	Grill Nose 34 Ford White
LC105X00X213	Ignition D Box Red	LC120E01A040	Hood 34 Ford White
LC105X00X215	Ignition Coils Inex Approved	LC120E01X031	Grill 34 Ford Painted
LC105X00X217	Sprocket Adapter	LC120E02A010	Desk Lid-34 Ford CP-White
LC105X00X300	Setrab 910-8 Oil Cooler	LC120E11A020	Fender Left Front 34 Ford
LC105X00X303	Oil Cooler Bracket	LC120E12A020	Fender Left Rear 34 Ford
LC105X00X304	Oil Cooler Fan	LC120E21A020	Fender Front Right 34 Ford
LC105X00X311	Oil Cooler 3 Pass System 9" Fan Only	LC120E22A020	Fender Rear Right 34 Ford
		LC120G02A010	Deck Lid 34 Coupe
		LC120H01A030	Grill Nose 37 Dodge
LC105X00X313	Oil Cooler 3-Pass Only	LC120H01A040	Hood – 37 Dodge White
LC1060	Heat Shield/Coil Mount	LC120M02A010	Desk Lid – Sedan White
LC1100	Rear Prop Shaft Short	LC120X003440	Fender Bracket AZ-40 40/34F
LC1101	Front Prop Shaft Long	LC120X00C037	Fender Bracket AZ-H Chevy
LC110E00X002	K Chassis 34 Coupe	LC120X00F037	Fender Bracket AZ-1 37 Ford
LC110M00X001	Legends Chassis Sedan	LC125X00X002	Lower A-Arm Left
LC110X00X000	Chassis Front Clip	LC125X00X003	Lower A-Arm Right
LC110X00X001	Chassis Rear Clip	LC125X00X020	RR Panhard Bar 23.5
LC110X00X120	Front Bumper Painted – 600 Racing	LC125X00X021	RR Tie Rod Strut Arm 11 Alum"
LC110X00X121	Rear Bumper Painted – 600 Racing	LC125X00X022	RR Rear Trailing Arm 12 Alum"
LC110X00X150	Nerf Upright PC – Left Short	LC125X00X023	RR Upper Rear Link 6.5 Alum
LC110X00X151	Nerf Upright PC – Right Short	LC135X00X100	Bassett Wheel Black
LC110X00X152	Nerf Upright PC – Long	LC135X00X101	Bassett Wheel Silver
LC110X00X153	Nerf Bar Coupe – Left	LC135X00X102	Chrome Plated Trap Wheel
LC110X00X154	Nerf Bar Coupe – Right	LC135X00X110	Black Elegant Trap Wheel
LC110X00X155	Nerf Bar Sedan – Left	LC140X00X407	R Diff Rich 2.93 W/Spool
LC110X00X156	Nerf Bar Sedan – Right	LC140X02X005	Axel Housing Double Shear
LC110X00X250	Steering Column Assembly	LC145X00X007	Brake Caliper Bracket
LC110X00X251	Lower 2/3 Steering Column assembly	LC145X00X008	Brake Caliper Plate
LC110X00X254	Upper Steering Column Shaft	LC490V01X002	Thunder Upper Arm Assembly
LC110X00X261	Steering Rack	LC925X00X114	Legends Shock
LC115X00X021	Running Board Left	LC925X00X204	Spindle Arm
LC115X00X022	Running Board Right	LC925X00X206	Spindle Base
LC120A01A040	Hood 37 Chevy	LC955X00X013	Fuel Pump 3#
LC120A01X031	Grill 37 Chevy Painted		
LC120A10A000	Body 37 Chevy Sedan Left		

10.1 to 10.9 Diagrams Depicting either mandatory or optional additions to frame or components. Diagram no. 1 or no. 2

10.1 DOOR PLATES

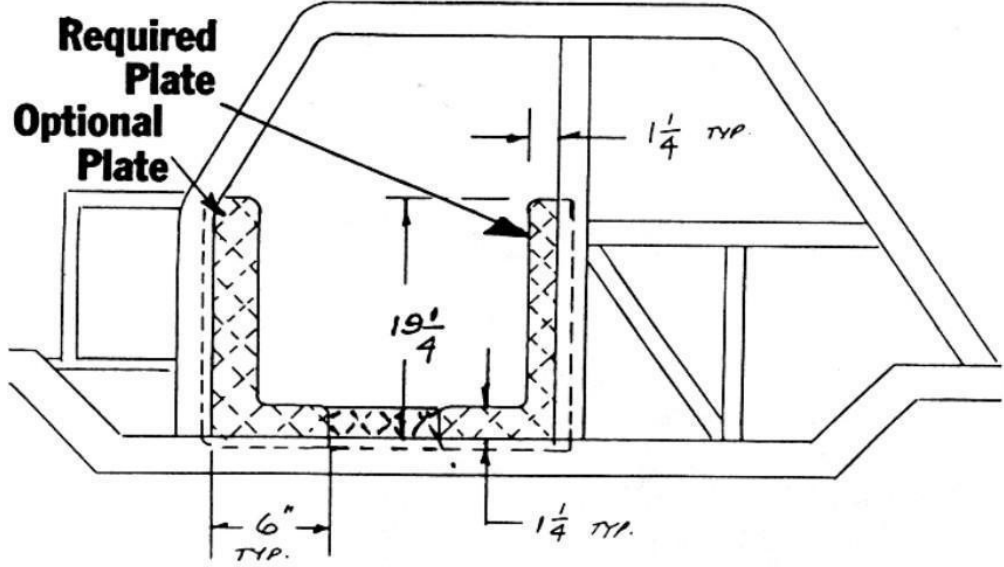
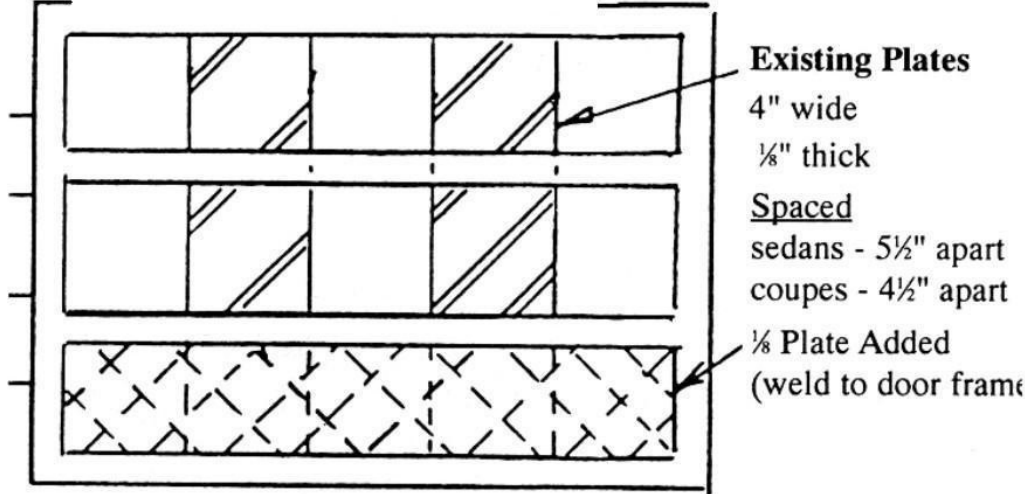

## 10.2 MANDATORY ROOF BRACES

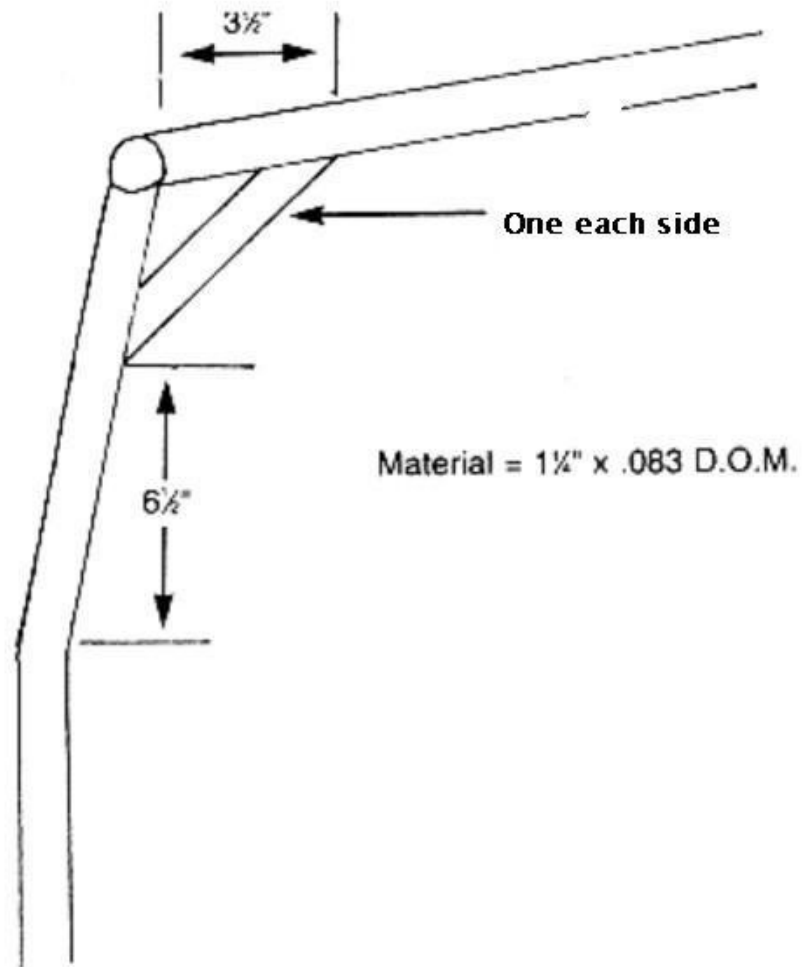

## 10.3 OPTIONAL ADDITIONAL FRONT PLATE

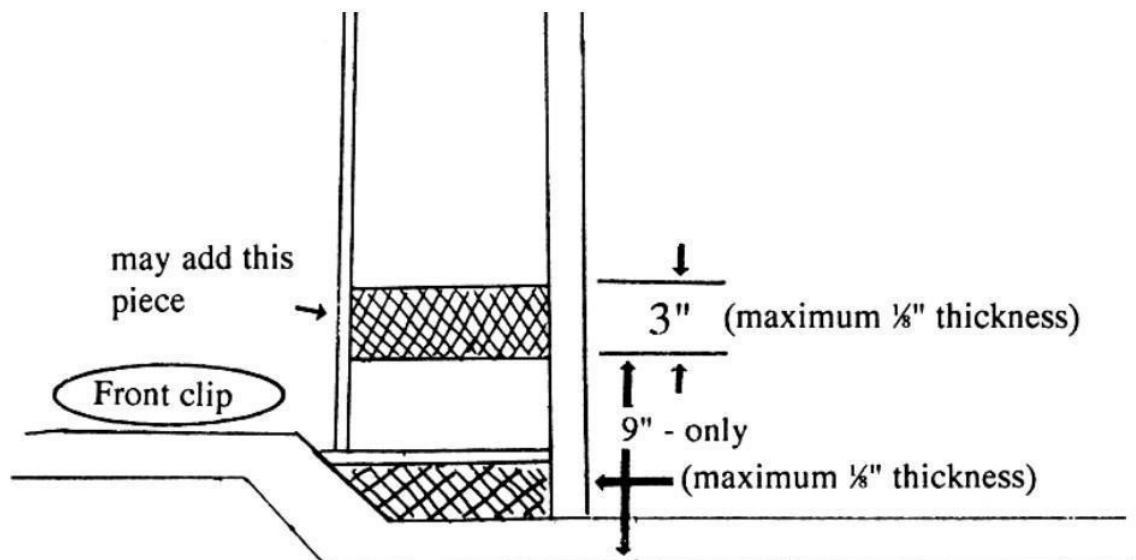

## 10.4 OPTIONAL ADDITIONAL REAR GUSSETS

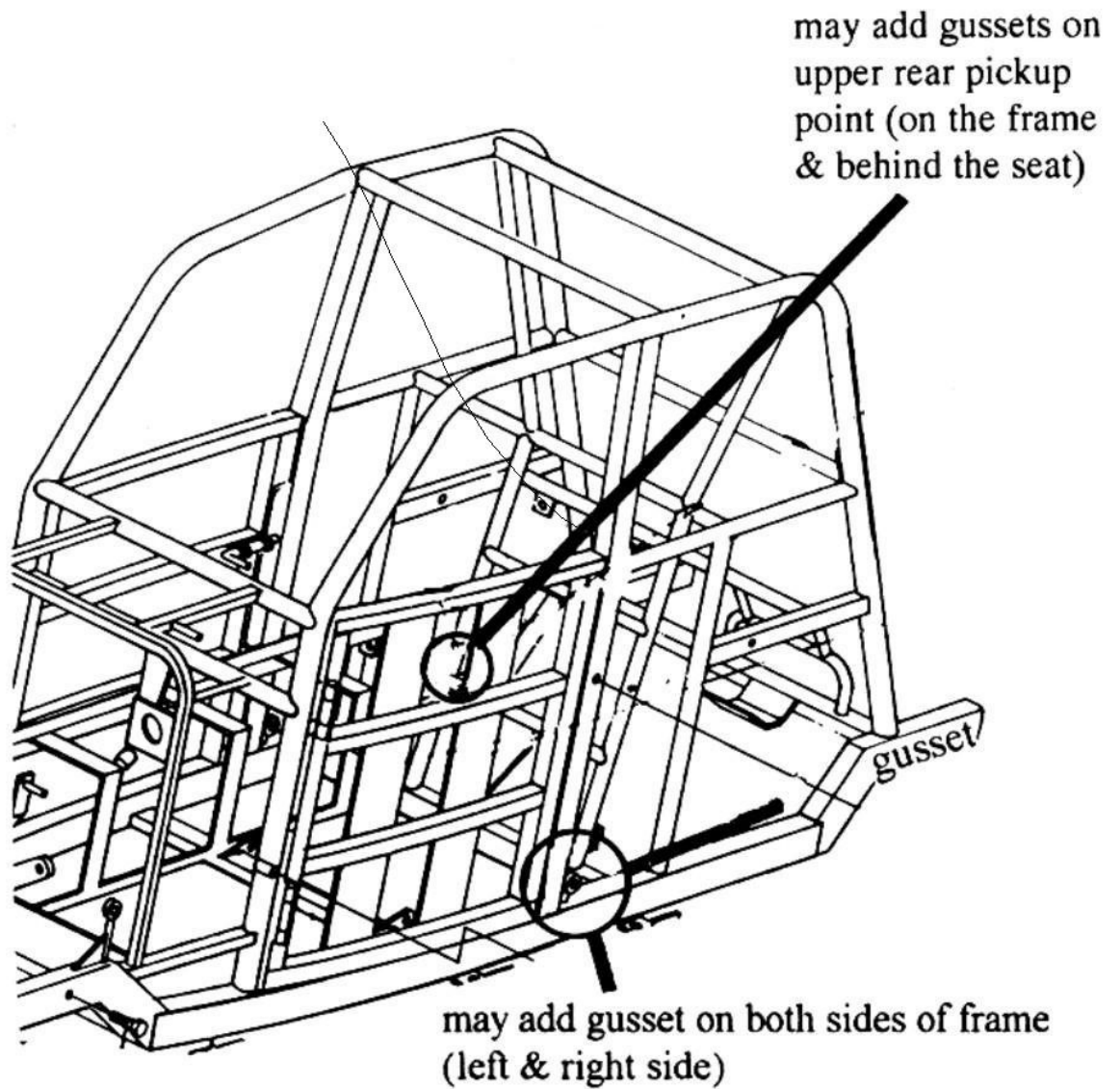

## 10.5

### FRONT CLIP – PERMITTED GUSSET RE-INFORCEMENT

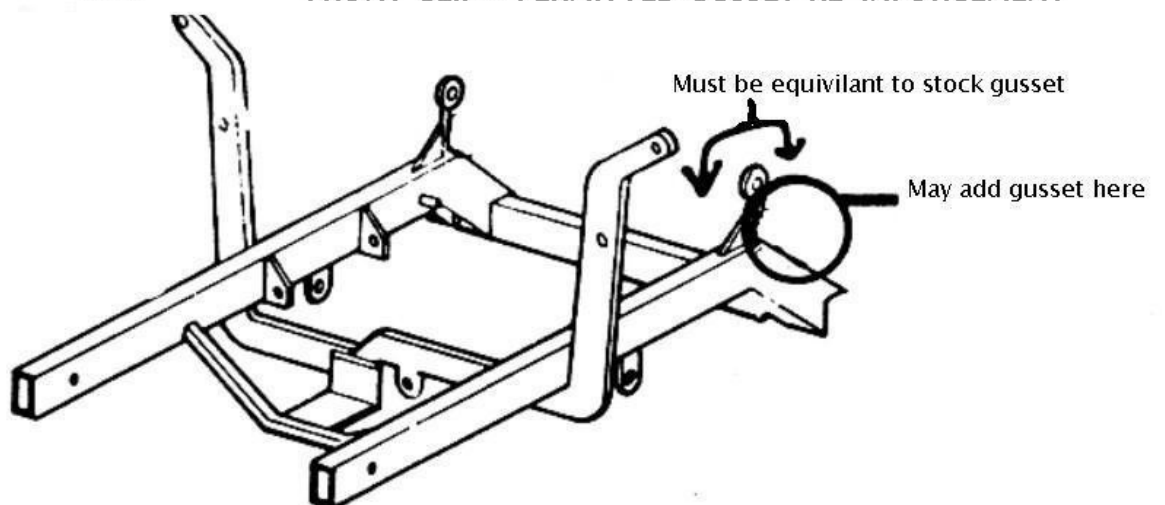

10.6 REAR AXLE

Rear gussets approved (Max.1/8" thick)

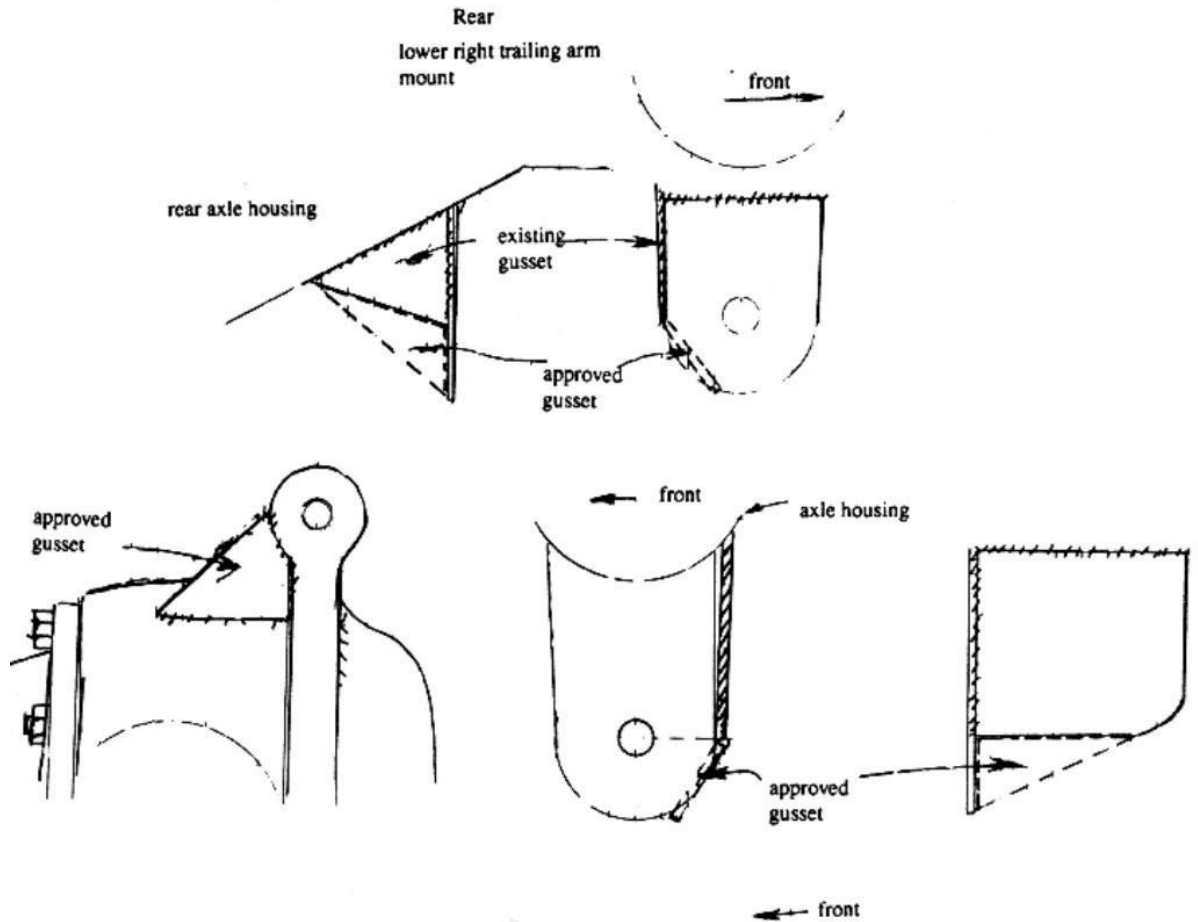

10.7 STEERING RACK PLATE

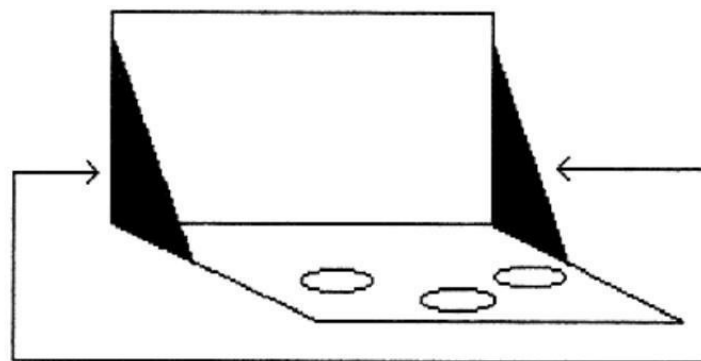

**Approved Additional Gussets**

(1/8" Max. Thickness Gusset)

10.8 MANDATORY  
STEERING COLUMN CLAMP  
& ADDITIONAL REAR STRUT

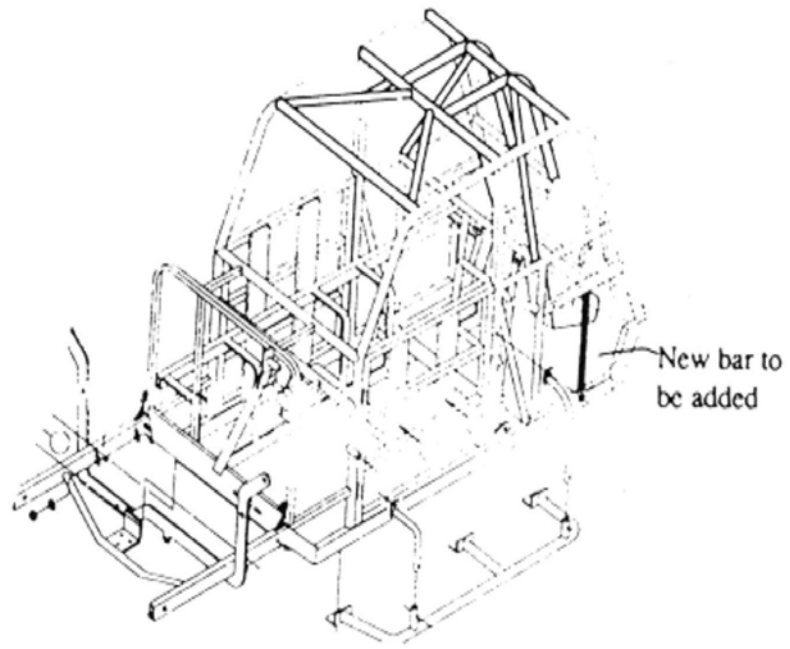
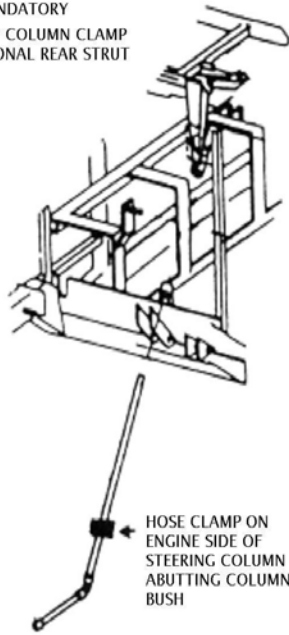

10.9 ADDITIONAL REINFORCEMENT REAR AXLE

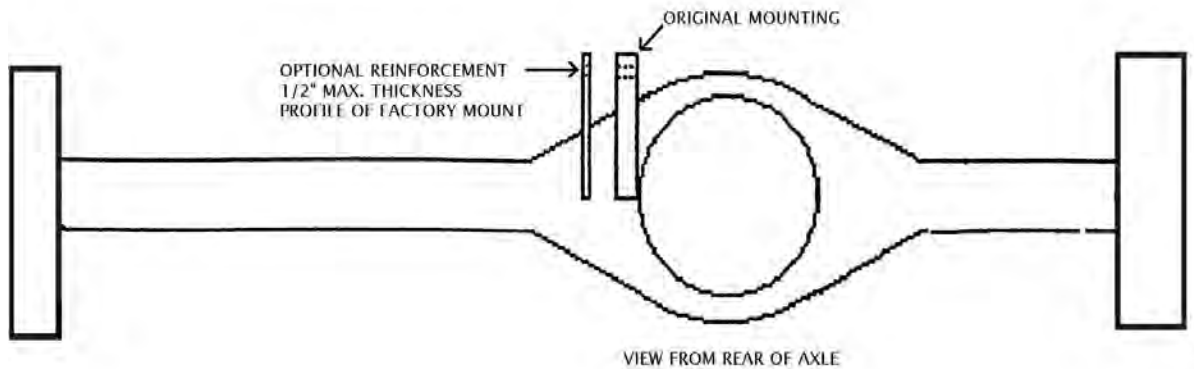

**FOLLOWING DIAGRAMS ARE STOCK SPECIFICATIONS  
OF SOME COMPONENTS OF LEGENDS CARS.**



## LEGENDS & THUNDER ROADSTER REAR END HOUSING

SPECIFICATION FOR INFORMATION ONLY

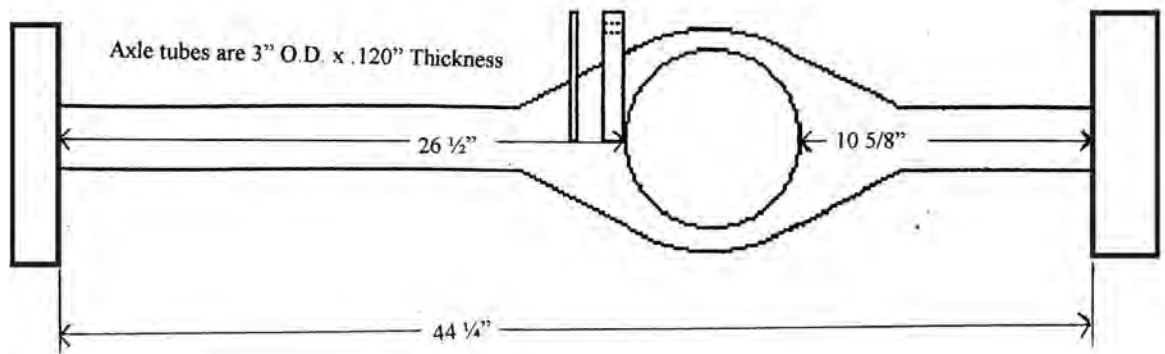

## LEGENDS SHOCK TOWER

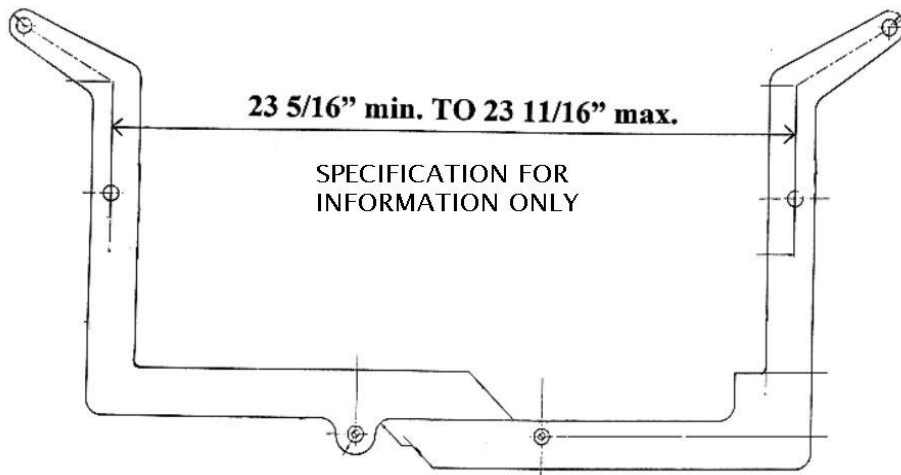

## LEGENDS LEFT SIDE MOTOR MOUNT PICKUP POINTS & FRONT CLIP MEASUREMENTS

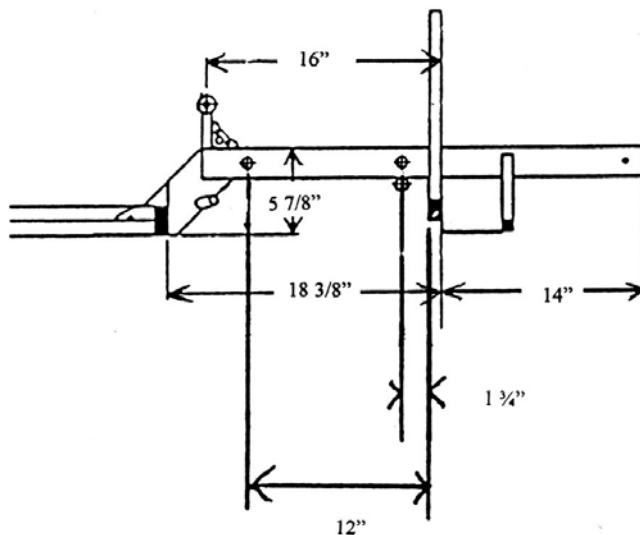

LEGENDS RIGHT SIDE MOTOR MOUNT

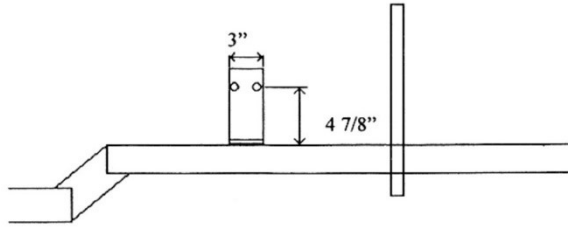

NOTE: ALUMINUM MOUNTS OR EXTRA HOLES ARE ILLEGAL

LEGENDS FRONT & REAR BUMPER

( 1" STEEL TUBE ) ( 8 lb. MAX. WEIGHT )

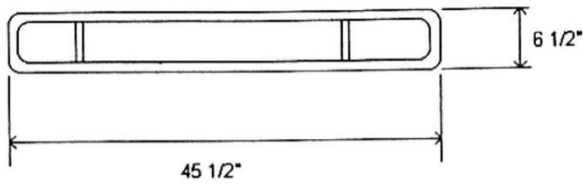

LEGENDS RIGHT & LEFT NERF BARS

**(WEIGHT = 4 lbs. MAX.)**



LEGENDS & THUNDER ROADSTER SPROCKET ADAPTER

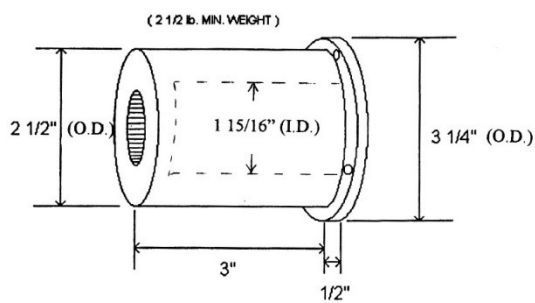

LEGENDS & THUNDER ROADSTER AXLES

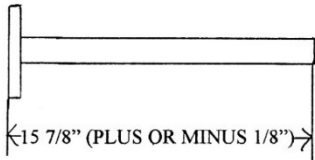
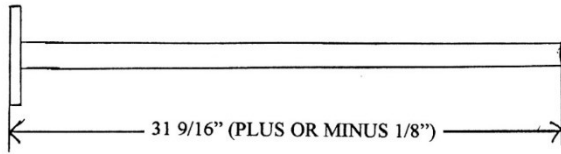

LEGENDS & THUNDER ROADSTER SPINDLE, LEFT & RIGHT

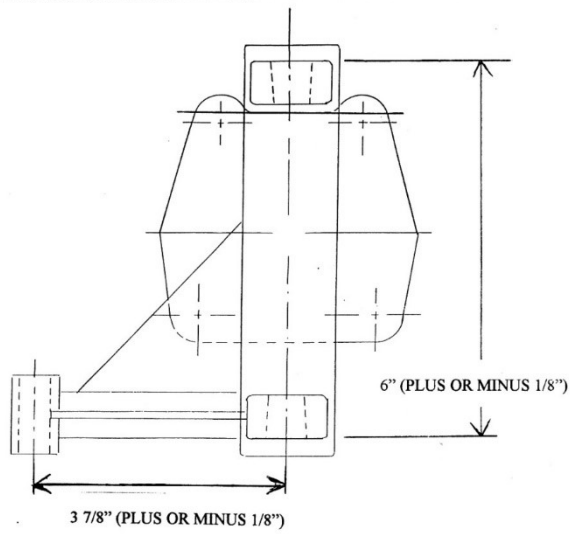

# LEGENDS UPPER CONTROL ARM FRONT MOUNTING POINT

SPECIFICATION FOR INFORMATION ONLY

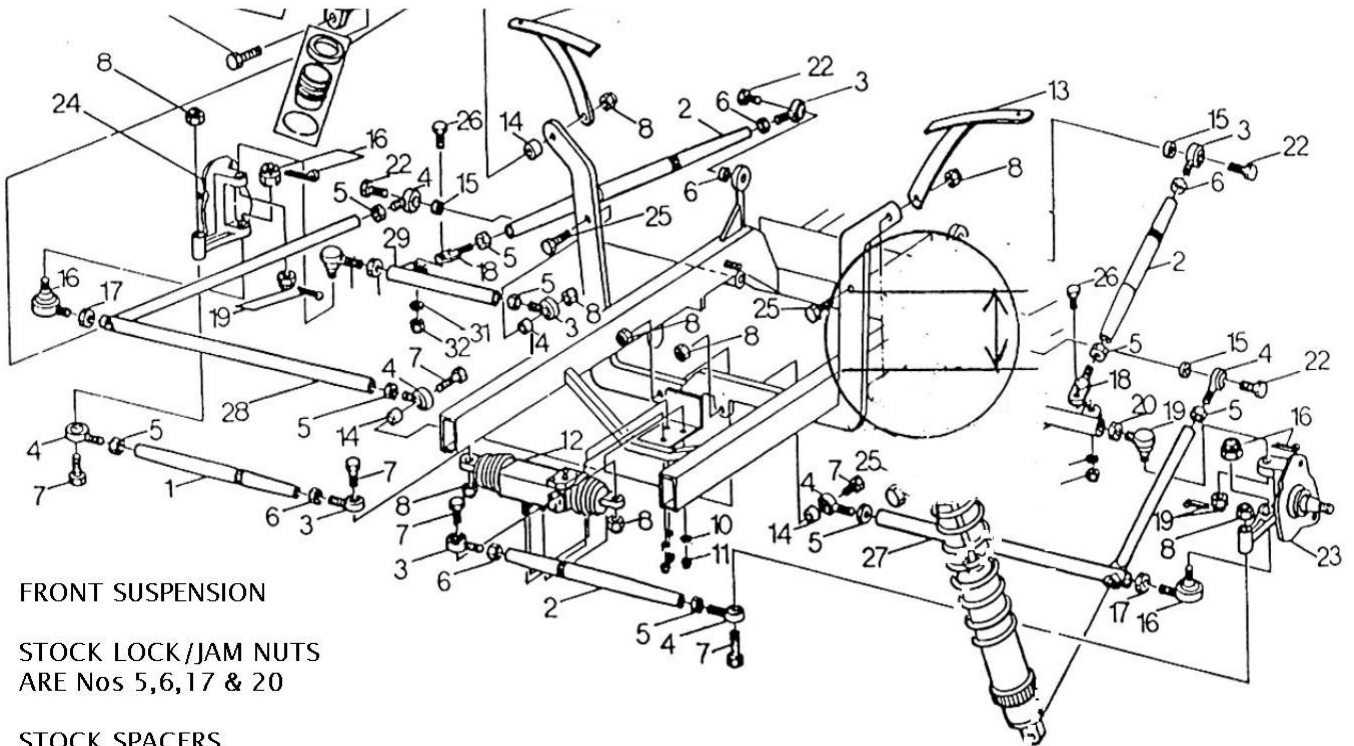

FRONT SUSPENSION

STOCK LOCK/JAM NUTS  
ARE Nos 5, 6, 17 & 20

STOCK SPACERS  
ARE Nos 14 & 15

DISTANCE OF PICK-UP POINT TO TOP OF FRAME  
3 5/8" +/- 1/8" TO CENTRE LINE OF HOLE

## LEGENDS SUSPENSION PICKUP POINTS

SPECIFICATION FOR INFORMATION ONLY

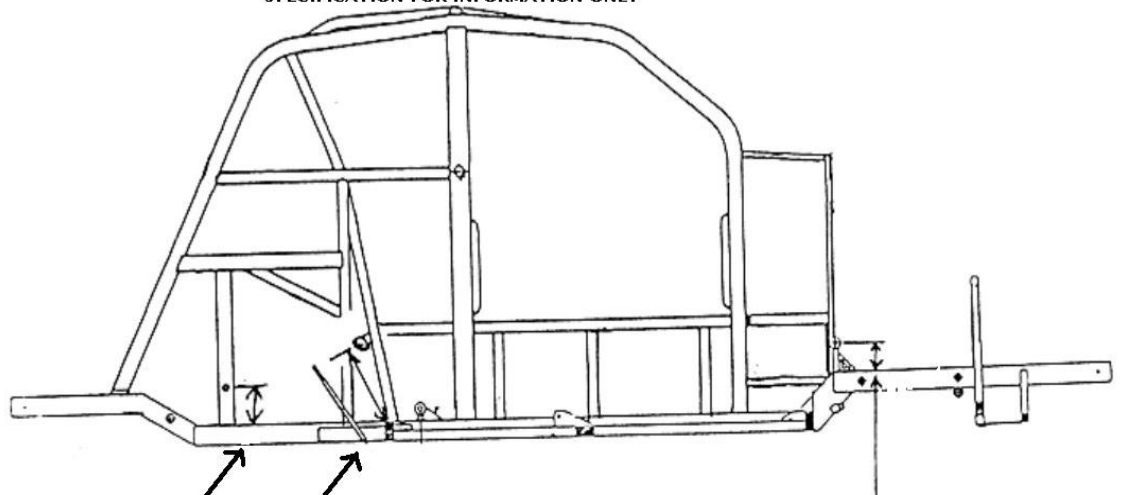

UPPER CONTROL ARM, REAR MOUNTING POINT:  
2 15/16" (PLUS OR MINUS 1/8" - FROM THE TOP OF THE FRAME TO THE  
CENTER OF THE BOLT)

UPPER LINK MOUNT:  
9" (FROM THE TOP OF THE CROSSMEMBER TO THE CENTER OF THE BOLT)

PANHARD ROD MOUNT:  
3 1/2" (FROM THE TOP OF THE CHASSIS TO THE CENTER OF THE BOLT)

LEGENDS LEFT SIDE MOTOR MOUNT

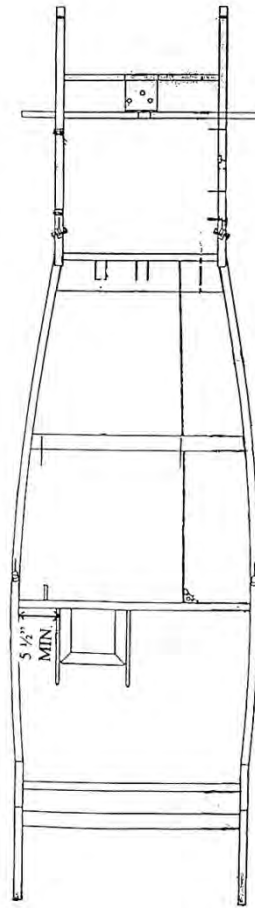
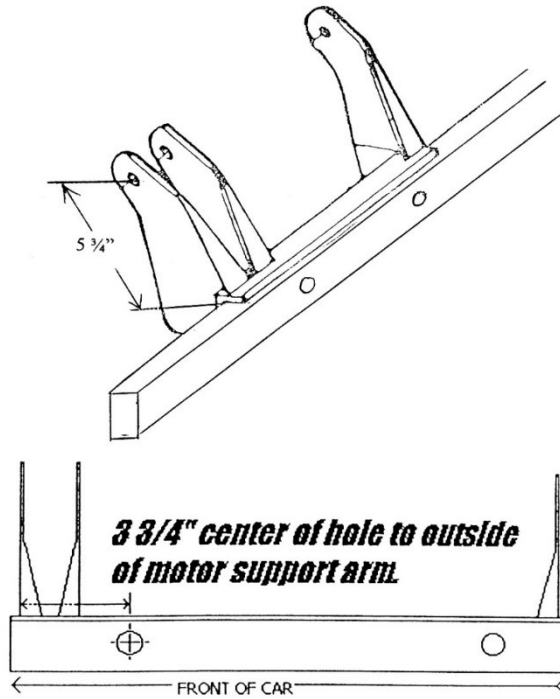

Note: The measurement for the battery box offset will be taken at the point closest to the crossmember, from the inside of the frame rail to the outside of the battery box.

STOCK YAMAHA CAMSHAFT

**STRESS RELIEVING THE CAMSHAFTS**

INEX has approved polishing the shaft of the cam in these areas (for stress relieving purposes only).

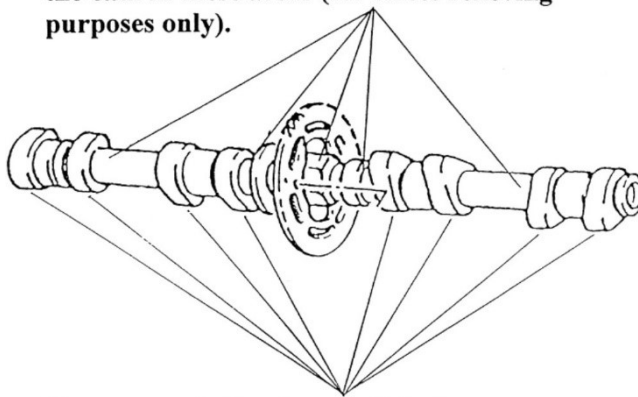

You may not alter the cam lobe in any way. (The sides of the cam lobe must remain untouched, with casting marks on them).



motor  
sport  
UK



**III. OFFICIAL STOCK ENGINE SPECS  
& TOLERANCES of the Yamaha  
FJ1200 / XJR1200:**

**Engine Type:** Air cooled 4-stroke gasoline  
**Carburetor:** BS36 x 4/Mikuni  
**Displacement:** 1,188 cm<sup>3</sup> (max. 1,203 cm<sup>3</sup> permitted)  
**Bore:** 77.0 mm (3.032 in.) with a max. .022 in. overbore permitted.  
**Stroke:** 63.8 mm (2.512 in.)  
**Compression Ratio:** 9.7:1 (max. 10.0:1 permitted)  
**Starting System:** Electric Starter  
**Cam Shafts:**  
   Intake "A" 35.95 to 36.05 mm (1.415 to 1.419 in.)  
   min. limit 35.85 mm (1.411 in.)  
   Intake "B" 28.25 to 28.35 mm (1.112 to 1.116 in.)  
   min. limit 28.15 mm (1.108 in.)  
   Exhaust "A" 35.95 to 36.05 mm (1.415 to 1.419 in.)  
   min. limit 35.85 mm (1.411 in.)  
   Exhaust "B" 28.25 to 28.35 mm (1.112 to 1.116 in.)  
   min. limit 28.15 mm (1.108 in.)

**DIAGRAM OF CAM SHAFT LOBE**

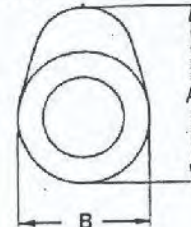

**Cam Chain:**

Type/# of lobes 79RH2015 (Silent Chain)/156 links  
 Adj. method Automatic (Manual is permitted)

**Valves:**

**Head Diameter:**

Intake: 28.9 to 29.1 mm (1.138 to 1.146 in.)  
 Exhaust: 24.9 to 25.1 mm (0.980 to 0.988 in.)

**Stem Outer Diameter:**

Intake: 5.475 to 5.490 mm (0.2156 to 0.2161 in.)  
   min. limit: 5.445 mm (0.2144 in.)  
 Exhaust: 5.460 to 5.475 mm (0.2150 to 0.2155 in.)  
   min. limit: 5.430 mm (0.2138 in.)

**Guide Inside Diameter:**

Intake: 5.500 to 5.512 mm (0.2165 to 0.2170 in.)  
   max. limit: 5.550 mm (0.219 in.)  
 Exhaust: 5.500 to 5.512 mm (0.2165 to 0.2170 in.)  
   max. limit: 5.550 mm (0.2190 in.)

**Transmission:**

Type: Constant mesh, 5-speed  
 Gear Ratio: 1st - 40/14 (2.857)  
               2nd - 36/18 (2.000)  
               3rd - 33/21 (1.571)  
               4th - 31/24 (1.291)  
               5th - 29/26 (1.115)





34 coupe firewall to lower rear cross bar  
From the fire wall to rear cross bar 44 in



34 coupe. Rear cross to b- post  
Rear cross to b-post is 8in



Seat back bar from b-post is 12 in



13in from upper link to petrol tank bar

## 7.0 REGISTRATION FORM:

Competitors are required to register by completing the online registration form at <https://knockhill.alphatiming.co.uk/users>





A socially-minded standard of behaviour is expected from everyone within the motorsport community.

By participating in a Motorsport UK Event in any capacity you agree to follow the values of the Respect Code:

[Motorsportuk.org/racewithrespect](https://Motorsportuk.org/racewithrespect)  
[#RaceWithRespect](https://twitter.com/RaceWithRespect)

### The Values

- Respect
- Fair play
- Integrity
- Good Manners
- Self-Control

I pledge to #RaceWithRespect and:

- Contribute to a welcoming and friendly environment that ensures the safety and welfare of all participants.
- Always behave with integrity and uphold fairness in the sport; play your part in keeping the sport safe through your actions
- Treat everyone with respect, regardless of their gender, ethnic or social background, language, religious or other beliefs, disability, sexual identity or other status
- Recognise that we all represent the sport and therefore have a duty to be polite and respectful to all staff, Officials, fellow Competitors, volunteers, as well as fans and supporters
- Respect the rules, regulations and authority of the Officials and Motorsport UK

Any breach of these obligations may result in disciplinary action.

## Car Technical Exception (2024)

Ref: **CTE-2024-053**

Motorsport UK can confirm that Knockhill Motor Sports Club has been granted permission to permit an exception from NCR Chapter 7 Appendix 2 Article 14 and NCR Chapter 7 Appendix 2 Article 77 in the Championship Regulations for the 2024 Scottish Legends Cars Championship.

**Date Approved:** 18<sup>th</sup> January 2024  
Reissued 2<sup>nd</sup> April 2024

Motorsport UK Signature:



**MICHAEL DUNCAN**

Technical Manager